

METALLIC DIAPHRAGM COMPRESSORS

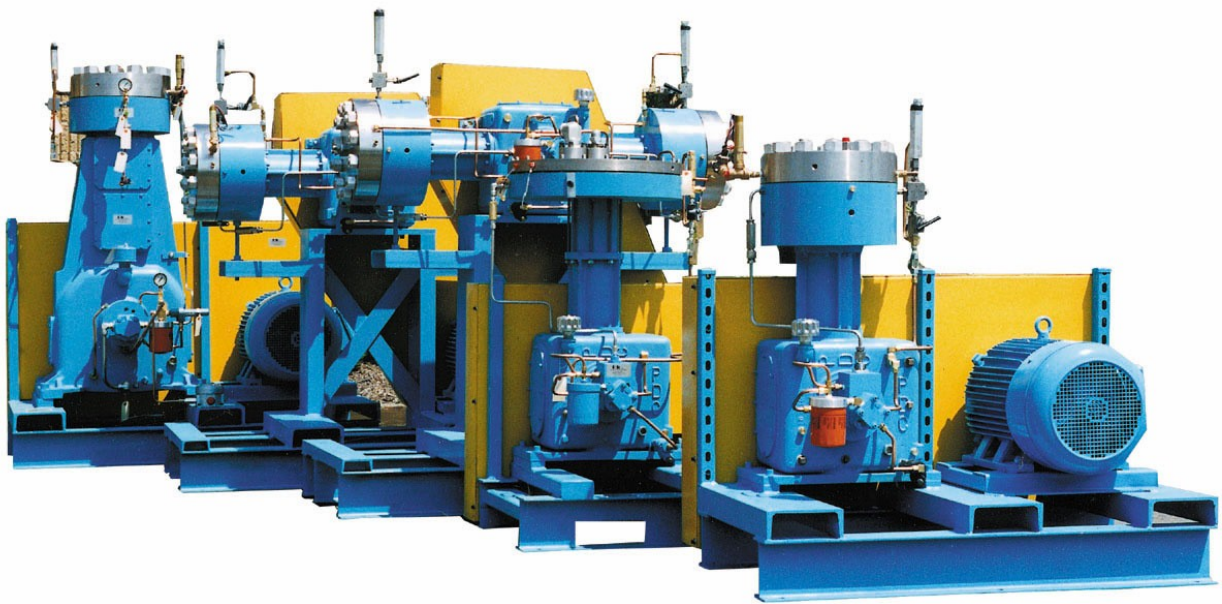

Manufactured with pride in the USA by:



An ISO 9001:2015 certified company.

**We perform
under pressure.**

**1875 Stout Drive
Warminster, PA 18974
Phone +1(215) 443-9442 Facsimile +1(215) 443-8530
E-mail: info@pdcmachines.com
World Wide Web Site: <http://www.pdcmachines.com>**

TABLE OF CONTENTS

Notes 4

Foreword..... 5

Introduction 6

Principles of Operation..... 7

Triple Diaphragm Leak Detection 8

Safety Precautions 9
 Cautions and Warnings 9

Receiving and Storage 12

Installation 13
 Inspection 13
 Location 13
 General Arrangement and Foundation Drawings 13
 Foundation and Anchoring for PDC 2, 3 and 4 Series Compressors 14
 Foundation and Anchoring for PDC 5 through 13 Series Compressors 14
 Foundation and Installation..... 14
 Grouting 17
 Final Shimming of the Unit..... 17
 Fastener and Fittings Torque Verification 18
 Piping – General Information 18
 Process Piping Connections 19
 Unloading Systems 19
 Cooling Water Piping 20
 Instrument Air 20
 Electrical Service Requirements 21

Operation 22
 Basic Safety Rules..... 22
 Preparation for Initial Startup 23
 Initial Start-up and Priming 25
 Shutting Down the Compressor 27
 Compressor Priming Requirements..... 27
 Restarting the Compressor 28
 Normal Compressor Operation 28

Back-up Compressor Operation	28
Standard Operating Procedures	29
Maintenance	30
Safety Precautions.....	30
Cleaning and Lubricating	30
Daily Maintenance Check List	31
Inlet Filter	31
Lubrication Systems	32
Frequency of Lubrication System Maintenance	33
Diaphragm and O-Ring Seal Replacement	34
Process Check Valves.....	37
Oil Inlet Check Valves.....	37
Hydraulic Oil Relief Valve	38
Hydraulic Oil Relief Valves	39
Setting the Hydraulic Oil Relief Valve.....	39
Compressor Base or Crankcase, Injection Pump and Head Assembly.....	40
Compressor Base Oil reservoir Volumes.....	40
Oil - Lubricants and Maintenance schedule.....	41-43
Troubleshooting.....	44
Drawings	45
Drawing A0020001 – Hydraulic Pressure versus Crank Angle Curve	45
Drawing A0020002 – Basic Compressor Components.....	46
Drawing A0020004 – Compressor Accessories	47
Foundation Figures.....	48
Typical Head Assembly Drawing	50
Flat Disc Check Valves.....	51
Cartridge Check Valves	53
High Pressure Relief Valve.....	55
Low Pressure Relief Valve.....	56
Injection Pump (typical)	57
Belt Tightening Procedures	58
Warranty Terms and Conditions.....	Error! Bookmark not defined.

Notes

This manual is written to cover all Metallic Diaphragm Compressor models manufactured at PDC, Please direct all questions regarding this manual or compressor systems manufactured by PDC to the plant located in Warminster, PA USA. Please provide the following information with all inquires, including spare part orders.

- ❑ PDC Job Number and Model Number which can be found in this manual or on the compressor nameplate.
- ❑ Your purchase order number and shipping information.

A recommended spare parts list is typically included in the Bill of Material titled "SP".

PDC, spare parts are provided specifically for diaphragm gas compressor systems engineered and fabricated by PDC, These parts are manufactured to their original tolerances and are designed to provide optimum dependability, performance and reliability. Our rigorous quality assurance programs assure high quality and consistency from part to part. All components are fabricated from carefully selected materials, whose characteristics are precisely controlled by our QC procedures.

PDC, can also provide the following services:

- ❑ Fully trained and qualified field service technicians can be dispatched worldwide to provide compressor repair, troubleshooting, general maintenance, etc.
- ❑ Evaluation and analysis of existing compressor systems for fitness, function or new applications.
- ❑ Start-up, commissioning and training activities.

PDC, remains dedicated to providing fast, professional service for our equipment providing our customer's with reliable gas compression systems for many years after their installation.

Manufacturing Plant Information:

PDC Machines
1875 Stout Drive
Warminster, PA 18974
USA

Phone Number +1(215) 443-9442
Facsimile Number +1(215) 443-8530, +1(215) 443-9543
Email Address info@pdcmachines.com

Additional Information is available on our World Wide Web site:

<http://www.pdcmachines.com>

Foreword

Metallic Diaphragm Compressors fabricated by PDC, are the direct result of state of the art engineering and manufacturing practices. They are designed to provide reliable, dependable service for many years. However, in order to maximize performance, the user must exercise care in its operation and maintenance. This manual recommends regular preventive maintenance procedures, proper operational procedures, etc., which must be carefully adhered to for reliable, economical performance with minimal down time.

Introduction

PDC Metallic Diaphragm Compressors are designed to pump gases in a contamination free or pure state. Since the pulsing media (hydraulic oil) and the process fluid being pumped are separated by a set of three metal diaphragms, contamination of the process fluid is avoided.

Contoured cavities are used to restrain diaphragm deflections and limit membrane stress as a result of being stretched into the contours. The cavity and diaphragm designs focus on high reliability and extended diaphragm life. The contoured cavity design is optimized using state of the art computer software and Finite Element Stress Analysis (FEA) techniques to provide uniform stress distribution within the established design limits.

The inherent design, i.e., the large surface area of the heads in contact with the process, allows diaphragm compressors to achieve high compression ratios. Clearance volumes are minimal and fixed, as opposed to adjustable, providing high efficiency without the need for sophisticated clearance volume adjustment mechanisms found in piston compressors. Thus compression ratios as high as 100:1 can be achieved, if necessary. In the certain cases, compression is very close to isothermal, as opposed to adiabatic, when compared to a standard piston compressor.

PDC supplies Metallic Diaphragm Compressors in stand-alone configurations, or, as completely integrated, skid mounted compressor systems, manufactured in accordance with the end users requirements and specifications.

Process wetted portions of Metallic Diaphragm Compressors can be manufactured from any machinable metal or alloy, which provides compatibility with the end users process fluid. Standard materials of construction are 304/316 SS, or, in other materials such as Inconel, Monel, Hastelloy, etc. Diaphragm material selection is limited to the commercial availability of material with the proper physical requirements necessary for acceptable diaphragm performance.

Principles of Operation

Please refer to our drawing A0020002, which includes the basic components of a diaphragm compressor. This example illustrates a single stage unit, but the same principles can be applied to each stage of compression in a compressor system. Drawing A0020001 also shows a typical hydraulic oil pressure versus crank angle curve.

Please note that the diaphragm set follows the hydraulic piston, or column of hydraulic oil, as it sweeps the cavity machined in the compressor heads. The relationship between the piston displacement and cavity volume is very critical and carefully designed and controlled.

The sequence of compressor operation is as follows:

- ❑ During the inlet stroke, the hydraulic piston moves towards the bottom dead center (BDC) position causing the pressure in the cavity to decrease as the diaphragm moves toward the bottom of the cavity.
- ❑ When the pressure in the cavity is below the inlet pressure to the compressor, the inlet check valve opens and permits gas to flow into the cavity. This is represented by the dip in the pressure versus crank angle curve at about 45°.
- ❑ Gas will continue to flow into the cavity until the piston reaches BDC.
- ❑ As the piston reverses direction and begins to move upward, the inlet check valve closes and the compression cycle starts.
- ❑ As the pressure in the cavity exceeds the compressor outlet pressure, the outlet check valve opens and gas flows at discharge pressure out of the compressor. The outlet check valve opening is represented by the pressure peak on the pressure versus crank angle curve at about 225°.
- ❑ The outlet flow will continue until the piston reaches the Top Dead Center (TDC) position at which point the piston reverses and the cycle repeats.

PDC utilizes a phased injection pump, which is driven by the crankshaft. This pump injects hydraulic oil into the cavity during the inlet stroke of the compressor.

The injection pump makes up for the oil loss in the system such as leakage past the piston, plus the amount of oil displaced over the oil relief valve during normal operation. The hydraulic relief valve setting is slightly higher than the outlet pressure of the compressor. This allows the diaphragms to contact the top of the cavity firmly, thus, assuring a complete sweep of the entire cavity volume. When the diaphragms contact the top of the cavity, the hydraulic piston still has a few degrees of crank angle left before it reaches TDC. During this period, the oil pressure rises above the compressor outlet pressure until it reaches the setting of the oil relief valve. At this point, the relief valve opens and oil, in the amount of the injection pump displacement less the losses in the system, is displaced over the relief valve. This oil flow is what is known as over pump. The relief valve opening is represented by the highest pressure peak on the pressure versus crank angle curve right before 360°.

Triple Diaphragm Leak Detection

Drawing A0020002 shows a graphical and schematic representation of the Triple Diagram Leak Detection Concept.

A leak detection system is standard equipment on every stage of compression for PDC Metallic Diaphragm Compressors. This system detects diaphragm failure, (cracked diaphragm), gas and/or oil seal failure. The diaphragm failures are normally attributed particles or contamination in the gas or oil systems of the compressor, moisture condensation inside the cavity, or improper tightening of the compressor head bolts.

The leak detection system concept utilizes a set of three (3) diaphragms, a closed chamber into which leaked media (gas or oil) accumulates, a leak detection, process and oil "O"-ring seal, a relief valve, a pressure gauge, pressure switch, and a normally closed manual blow down valve.

The middle diaphragm is manufactured with leak grooves to allow media to pass into the leak chamber. If the diaphragm is cracked, the gas or oil will penetrate through the crack, pass through the leak grooves in the middle diaphragm and then enter the closed leak chamber. As the gas or oil is accumulated, the pressure increases. The pressure switch is set at 15 psig on increasing pressure and is typically used for interlock shut down of the compressor via the motor control system. The pressure gauge is used for visual indication of a leak, the relief valve protects the system from excessive pressure and the manual valve allows the operator to vent off the leak for maintenance and verification purposes. Care should be utilized to assure that hazardous process media vents, including leak detection vents, are properly routed to safe vent areas.

In some compressor systems the entire leak detection system is assembled together and mounted directly to the compressor head assembly. In other systems, the pressure gauge and vent valve may be remotely mounted on a common operator control panel.

Safety Precautions

Safety is everyone's concern and is based on the use of practical common sense and the adherence to applicable safety codes and standards. Because a Metallic Diaphragm Compressor is a large, high-speed reciprocating piece of machinery, common sense precautions for this type of machinery should be observed, as carelessness in operation or maintenance is hazardous to personnel.

In addition to the many obvious safety rules that should be followed with this type of machinery, we suggest the following:

Cautions and Warnings

Warning: Failure to observe the various warnings in this manual could result in injury to or death of personnel, and or damage to compressor equipment.

- ❑ Do not operate the compressor unit without reading and understanding the Installation/Operational and Maintenance Instruction Manual. Contact PDC for any questions or clarifications regarding the manual.
- ❑ Keep fingers and clothing away from revolving or reciprocating parts.
- ❑ Do not loosen or remove any parts in the compressor process, lube oil or cooling systems until the compressor has been safely shut down and properly isolated from supporting equipment.
- ❑ Electrical shock can and may be fatal.
- ❑ The compressor electrical control systems and sub systems must be installed in accordance with the appropriate International, National or Local Code requirements and rated for the applicable electrically classified environment. Refer to the Compressor Data for compressor system ratings.
- ❑ The compressor should be properly grounded.
- ❑ Disconnect, tag and lockout the compressor power source prior to working on the unit.
- ❑ Properly shut down the compressor prior to making repairs or adjustments on or around the compressor.
- ❑ Do not exceed the rated maximum operating conditions specified in the Compressor Specifications or Data Sheets. This warning applies to the compressor and all its support equipment.
- ❑ Do not operate the compressors without the proper guards in place.

Cautions and Warnings (continued)

- ❑ Do not operate the compressor without installing the compressor as defined in this manual and other supporting documents, as well as in accordance to any International, National or Local Occupational Safety and Health Codes. Minimum recommended fail safe controls for a compressor system should include motor overload protection, leak detection system, cooling water flow switch, compressor base oil pressure switch (except for splash lubricated compressor bases) and appropriate process system interlocks. PDC can supply completely integrated compressor systems with all of the above fail safe controls, however, if these controls are not provided by PDC, the end user is responsible for their installation.
- ❑ Generally, do not start compressors under load as this will result in oil priming difficulties, cavitation and excessive vibration. There are many ways to design and provide unloading systems for compressors depending on the process fluid being handled. In most cases, PDC-2, 3 and 4 series compressors can be started under load, without the use of an unloading system. Refer to the Compressor Specification Sheet to determine if your compressor requires an unloading system. Consult the factory for recommendations if you have any questions regarding unloading requirements.
- ❑ Check torque on all bolts prior to operation of your compressor. Torque for individual fasteners can be found in the assembly drawings found in this manual or marked on the compressor itself. Use proper tools when applying torque to bolts. Do not over torque bolts.
- ❑ Pressure test all process lines with an inert gas such as N₂ prior to introducing process gas into the compressor. Your compressor has been fully tested at the factory, however, during transportation; it is not uncommon for joints to loosen.
- ❑ Do not operate the compressor without the proper inlet filtration installed. Minimum filtration requirements are 5-10 micron nominal particle filtration and the filter should be sized such that the pressure drop does not exceed 2% of the suction line pressure. Separation or filtration prior to the compressor inlet must remove any particulate or moisture present in the process media.
- ❑ Do not operate the compressor without adequate cooling water flow to the compressor heads and associated coolers.
- ❑ Do not operate the compressor with Suction pressure higher than the Discharge. First equalize the suction and discharge then start the compressor.
- ❑ Never operate the compressor, or any other equipment, without the proper safety protection devices and fail safe controls installed and functioning correctly. Safety and fail safe devices should be periodically checked for proper operation and general fitness and function. Never bypass safety or fail safe devices.
- ❑ Never tighten bolts or fittings while under load due to pressure.
- ❑ Observe all facility-implemented procedures during maintenance such as lockout, tag-out procedures, work permits, protective clothing and gear, etc.

Cautions and Warnings (continued)

- ❑ Provide the proper freeze protection if the compressor will operate in cold environments. PDC can provide crankcase heaters and heat tracing upon request. Use additives in the cooling water to prevent freezing in the compressor heads and cooling lines during periods of inactivity. Freezing media in the compressor heads and cooling lines will cause failures
- ❑ Do not use a compressor for any process fluid media other than those specified in the "Compressor Specifications Sheets". Consult the factory for information regarding different process media.
- ❑ Only use factory approved lubricants for your compressor.

Receiving and Storage

All Metallic Diaphragm Compressors are thoroughly inspected, carefully packaged on a wood skid and wrapped in plastic prior to shipment from PDC. Inspect the skid carefully, as soon as it is received at your facility. Any damage to the skid and or the compressor itself should be reported to the shipping service immediately.

Store the compressor in its original skid in a dry and clean location where it is protected from rain, snow and extreme environments. The temperature of the storage area should be between 50 and 100°F.

If storage is required for an extended period, the following precautions should be observed:

- ❑ Oil and elastomeric seals have a shelf life of approximately one year. Replace these if necessary before startup.
- ❑ Moisture condensation can take place when temperature drops excessively. Moisture condensation can cause corrosion damage to the various precision parts of the compressor. Take the necessary precautions and perform routine checks to avoid such damage. Replace oil as required to maintain adequate lubricant levels.
- ❑ Due to relative motion cause by vibration from the surrounding environment, fretting corrosion can occur when a compressor sits in one place for an extended period of time, especially in the bearing areas. Rotate the flywheel every 20 to 30 days so that the oil film is restored between the bearing rollers and races to prevent fretting corrosion of the bearings and other surfaces.
- ❑ Units shipped from the factory have all openings temporarily sealed for protection. Do not remove these seals until the compressor is ready to be installed.

Installation

Inspection

Receive or remove from storage the compressor per Section 2 of this manual. Unpack the compressor and carefully inspect the compressor for damage corrosion or other adverse effects from shipping or storage. Remove any temporary connection covers, seals or shipping support mechanisms, which should be clearly marked as temporary.

Location

The compressor should be located in an area of sufficient size to permit cleaning, maintenance, and disassembly of the compressor. The compressor installation site should be located in an area that is accessible to the process fluid media being pumped, cooling water service, electrical service, compressed air service and fluid drain system. The mounting surface should be level, hard and dry, such as a concrete floor or foundation.

Avoid mounting compressors on upper levels of mezzanines unless the mezzanine has been designed to accommodate reciprocating machinery.

General Arrangement and Foundation Drawings

General arrangement and foundation drawings for your compressor can be found in this manual in the "Engineering Drawing Section". The general arrangement drawing provides overall size information, weights, unbalanced forces, etc. In the case of smaller compressors, the foundation information will also be on the general arrangement drawing. For larger compressors, a foundation drawing will be provided. These drawings provide information from the floor up only.

Generally speaking, reciprocating compressors cannot be designed and fabricated to be completely counterbalanced. The foundation must be designed to support the weight of the compressor and to absorb unbalanced forces. An inadequately designed foundation will result in excessive vibration and or movement of the compressor during operation.

Note: The responsibility for an adequate foundation lies with the end user or installation contractor. The foundation is a poor place to economize. The extra cost for an adequate foundation is usually small and is always well justified.

Installation (continued)

Foundation and Anchoring for PDC 2, 3 and 4 Series Compressors

These compressors are relatively small and can be mounted securely to a level concrete foundation or floor (approximately 6" thick) using concrete anchors and the mounting holes provided on the bottom of the structural steel frame weldment of the compressor. For models PDC-4-100 and lower (i.e. PDC-4-50), reference PDC-5 through 13 foundation instructions due to the large size of the head and piston assemblies. Make sure the floor and bottom of the compressor are clean prior to mounting. Due to the inherent inconsistencies of both the concrete floor and the structural steel beams, there will be gaps between the floor and steel beams. Leveling shims must be inserted in these gaps so that the steel beams sit solidly on the concrete floor. When the compressor is correctly secured to the floor and leveled using shims, vibrations will be minimal. If vibration levels are excessive, recheck the shims and the mating surfaces between the compressor frame and the floor.

Foundation and Anchoring for PDC 5 through 13 Series Compressors

Foundation requirements for these compressors are significantly more involved due to their size and larger unbalanced forces. In these compressor series, PDC uses Gardner Denver/Joy reciprocating power frames fitted with PDC diaphragm head assemblies, and oil injection pump.

The following foundation information is typical information found in the Gardner Denver/Joy Installation manual for reciprocating compressors and should be adhered to:

Foundation and Installation

Foundation for reciprocating machines differs from foundation for buildings or similar structures since dynamic rather than static loads are involved. The foundation area should provide a soil bearing pressure of approximately 500 PSF or less. Low soil bearing pressures keep the natural frequency of the foundation high, prevent resonance, and reduce the possibility of transmitted vibrations.

Where hard limestone or other equally hard stone formations come to the surface, it will be sufficient to clean off Alluvial soils, unconfined sand or gravel, soft clay, silt or filled ground do not furnish satisfactory support for foundations of reciprocating compressors. When these soils are encountered, the foundation below the floor line must be made larger than normal or pilings may be necessary to provide vertical support.

The foundations must always contain sufficient reinforcing steel, must be extended below the frost line and should be completed in a single pour.

Installation (continued)

To help avoid transmission of vibration to the floors and walls of the compressor room, it must be isolated from the compressor foundation. The perimeter of the foundation below the floor should be surrounded with eighteen (18) inches of coarse dry gravel or by a narrow gap filled with asphalt or other suitable material.

Installation (continued)

Sleeves are placed around foundation bolts to permit flexibility when lining up and leveling the compressor prior to grouting. These must not be filled with concrete when pouring the foundation, but must be filled with grout when grouting the compressor. Sleeves around foundation bolts are considered necessary because they act as reinforcement and eliminate foundation cracking when the bolt is pulled tight.

All concrete surfaces to receive grout **MUST BE LEFT ROUGH** and **NOT** trowled smooth. If an extra deep foundation is required, or the compressor is set higher above the floor level than shown on the foundation drawing, the area of the base of the foundation must be increased. This is especially important since both conditions will promote rocking of the foundation.

The foundation should be allowed to cure for at least one week before the compressor unit is placed on it.

The conduit leads; water and air piping and drain facilities should be provided for in the design of the foundation.

When conditions are at all doubtful, or if the foundation is located where transmitted vibration might be objectionable, a foundation specialist should be consulted.

FOUNDATION BOLTS AND SLEEVES (FIGURE 1-3)

Foundation bolts must be accurately located and held while concrete for the foundation is being poured. This can be accomplished by using a rigid template to hold the bolts in the proper position and wiring them to the bottom so they remain plumb.

A sleeve, at least one inch larger than the bolt size, must be used to permit flexibility when lining up and leveling the compressor unit prior to grouting.

BOLTS AND SLEEVES MUST BE CLEAN AND FREE OF OIL.

SETTING AND LEVELING THE UNIT – Thoroughly clean the top of the foundation and the bottom of the compressor. Remove washers and nuts from foundation bolts. Make sure threads are not damaged. Remove plugs from the top of the foundation bolt sleeves.

Package, Skid or Base-Mounted Units – Package, skid or base-mounted units cannot be bolted to an ordinary existing floor. It is necessary to grout their bases to an adequate foundation.

1. Support the skid or base on metal wedges leaving a one-inch minimum space for grouting. Place wedges near each foundation bolt.
2. Place a level on top of the crankcase cover.
3. Drive wedges in small increments, in rotation, until the unit is at the correct height and level in both directions.
4. Securely tighten skid or base foundation bolts in rotation, checking the level to insure the skid or base has not been distorted or moved on the wedges.

Installation (continued)

Grouting

1. Build a wood form around the foundation above the crankcase feet, cylinder support sub base, motor sole plates or base or bottom flanges of steel base or skids as shown in FIGURE 1-1 & FIGURE 1-2, page 2. This will form a temporary dam for the grout.
2. Wet down the top of the foundation thoroughly, remove any puddles of water, and blow water out of the sleeves around the foundation bolts. A grout mixture of one part cement to two parts sand with enough water to allow grout to be poured is satisfactory. Too rich or "soupy" condition causes grout to crack or to have too much shrinkage. Commercial non-shrinking grout mixtures are available. These mixtures can be used if the grout manufacturer's recommendations are followed.
3. Fill sleeves around the foundation bolts with grout first and pack tightly, then work grout under crankcase, cylinder support sub base, motor sole plates, or base, or steel base, or skid and around foundation bolts.

CAUTION! Use care when working grout under the cylinder support sub base and motor sole plates or base so that grout does not go above their inner edges.

4. When grout has started to set, remove the forms and with a trowel, smooth and trim the grout to the foundation. Normally, it will take one or two days for the grout to thoroughly set. Metal wedges should be removed and openings should be patched.
5. The finished concrete surfaces should be sealed with a good water and oil-proof cement paint to prevent deterioration of the concrete.

Final Shimming of the Unit

Package, Skid or Base-Mounted Units

1. Remove shims from between the crankcase and base, cylinder support and base, and motor and base.
2. Recheck tightness of all foundation bolts.
3. Place a dial indicator on the crankcase feet near the bolt being tightened, similar to FIGURE 1-4, page 4. If deflection is greater than .003" shim accordingly.
4. Replace shims between the cylinder support and base so the dial indicator shows that the cylinder support has been raised approximately .005" to .010".
5. Securely tighten the cylinder support to the base. If the proper number of shims were used, the dial indicator should return to within $\pm .003$ " of zero. If not, repeat the procedure changing the number of shims used.
6. Use the same procedure for shimming between the motor and base.

Installation (continued)

Fastener and Fittings Torque Verification

Check all bolts, nuts, screwed fasteners and fittings for the proper torque or tightness, prior to operating the compressor. Although the compressor has been fully tested at the factory, vibration during transportation can cause things to become loose. Bolt and fastener torques can be found on the assembly drawings found in this manual or in some cases, marked on the compressor itself.

Piping – General Information

Provide appropriate materials of construction for the process fluid and other service media. The compressor materials of construction can be found on the Compressor Specification Sheets and Bills of Materials found in this manual. The Specification Sheets also contain information about service requirements.

Thoroughly clean all service lines to the appropriate level prior to installation. Remove all foreign particles from fabrication and assembly.

Adequate support must be provided for all connecting piping to avoid excessive nozzle loads and to isolate the compressor from any vibration generated by equipment up and down stream of the compressor. Piping systems should be designed to accommodate movement, which may occur as a result of vibration, temperature gradients, etc.

Provide isolation valves as required, to allow equipment isolation and safe conditions during maintenance activities.

Over pressure protection must be provided on the outlet side of the compressor and in all other service lines where over pressurization is a concern. Relief devices must be appropriately sized to meet the applicable codes and standards.

Pressure test all service and compressor piping prior to operation to assure fitness and functionality of piping systems. This can be done using inert gas such as helium, nitrogen or clean air. Take all necessary safety precautions during pressure testing. Never over pressurize any part of the compressor system as this could damage equipment and cause injury or death to personnel. Repair any leaks prior to operation.

Warning: Never tighten fittings or bolts while under a load due to pressure.

Installation (continued)

Process Piping Connections

The process piping schematic, or P and ID, can be found in the drawing section of this manual. This schematic represents the extent of the process system supplied with the compressor. Typically, process piping consists of the compressor inlet, outlet and vent connections. The size and type of connections provided on the compressor are listed on the drawing and tagged on the unit itself.

The line size servicing the compressor inlet and outlet should be the same size provided on the compressor, or preferably, one nominal size larger. The line sizes provided on the compressor have been carefully sized for the process conditions and the reciprocating nature of the flow. Do not use average velocity calculations to determine line sizes, as the instantaneous velocities during the compression cycle are considerably higher. If the compressor line sizes are too small, the compressor will not perform in accordance to specifications.

If the volume of the piping system is insufficient to prevent pressure fluctuations during operation, volume tanks or pulsation suppressors must be installed. If the compressor is a packaged unit, these devices may already be included.

Adequate inlet filtration must be used to protect the compressor. Do not operate the compressor without the proper inlet filtration installed. Minimum filtration requirements are 5-10 micron nominal particle filtration and the filter should be sized such that the pressure drop does not exceed 2% of the suction line pressure. Separation or filtration prior to the compressor inlet must remove any particulate or moisture present in the process media.

Unloading Systems

Refer to the Compressor Specification Sheet to determine if your compressor requires an unloading system. Generally, do not start compressors under load as this will result in oil priming difficulties, cavitation and excessive vibration. There are many ways to design and provide unloading systems for compressors depending on the process fluid being handled. In most cases, PDC-2 and 3 series compressors can be started under load, without the use of an unloading system. Consult the factory for recommendations if you have any questions regarding unloading requirements.

Installation (continued)

Cooling Water Piping

Refer to the Cooling Water Schematic drawing and Compressor Specification Sheets found in this manual, for information on the cooling system supplied with the compressor. Connection sizes, flow, pressure and temperature requirements, etc., are referenced in these documents. Cooling water service lines should be constructed from materials compatible with the cooling water media.

The compressor should be interlocked via a flow detection device, such that if there is a cooling water failure, the compressor can be shut down.

Provide the proper freeze protection if the compressor will operate in cold environments. Crankcase heaters and heat tracing can be provided by PDC upon request. Use additives in the cooling water to prevent freezing in the compressor heads and cooling lines during periods of inactivity. Freezing cooling media in the compressor heads and cooling lines will cause failures.

Over pressure protection must be considered if the cooling water system is isolated and allowed to heat up from exposure to sun light or other heat sources.

Instrument Air

Refer to the Pneumatic System Schematic drawing and Compressor Specification Sheets found in this manual, for information on the Instrument Air system supplied with the compressor. Typically, instrument air is used to actuate automated valves, control valves, etc. Pressure, flow capacities, line size requirements are defined in the drawings and specification sheets. Instrument air should be of high quality and free of contamination. Dirty instrument air can interfere with proper valve function.

Installation (continued)

Electrical Service Requirements

Refer to the Electrical Control Schematic drawing and Compressor Specification Sheets found in this manual, for information on the electrical control system supplied with the compressor. Voltage, power, environmental and other service requirements can be found in these documents.

Switchgear or other power distribution networks should be installed in accordance to the applicable electrical codes and rated appropriately.

Packaged systems are typically fully integrated. However, the user is responsible for assuring that the compressor is safely installed in accordance with all applicable Codes and Standards. As a minimum, the following interlocks are necessary to protect the compressor:

- High Discharge Pressure
- Low Cooling Water Flow
- Motor Overload
- Diaphragm Leak Detection (one for each stage of compression)
- Low Lube Oil Pressure (pressure lubricated frames)

Depending on the mode and style of operation, attended or unattended, etc., additional interlocks may be required for necessary for safe operation. Consult the factory for recommendations based on your specific installations.

When selecting the control system for automatic operation, it is important to note that the compressor should not start and stop any more than once every 15 minutes. It is not good practice to allow the compressor to cycle more frequently. The compressor capacity should be selected so that is not too large or small. Volume bottles, storage vessels, etc. can also be added.

As a standard, PDC compressors are designed for general-purpose industrial areas. Diaphragm compressors can be designed and fabricated for hazardous electrical areas. Refer to the Compressor Specification sheets for information regarding the electrical classification of your compressor.

Warning: Never install a compressor into a hazardous electrical area for which it is not rated.

Operation

Basic Safety Rules

- ❑ Operators must familiarize themselves with the compressor, controls, safety systems and starting equipment, prior to operating the compressor. Carefully read and understand the manuals, drawings and other technical information provided with the compressor.
- ❑ Before starting, be sure all protective guards are in place and clear of moving parts.
- ❑ Never leave the compressor unattended until you are sure all controls and safety devices are operating properly.
- ❑ Observe all safety precautions and rules. Follow the procedures established for operating the compressor.

The compressor system has been carefully designed, fabricated, inspected and fully tested under the appropriate factory conditions. Proper installation, operation and maintenance procedures must be followed in order to provide satisfactory service throughout the life of the compressor.

Operation (continued)

Preparation for Initial Startup

- ❑ Clean up the area in which the compressor is installed. Remove any oil, dirt and grease from the floor, which may have accumulated during installation. Discard empty containers or other foreign matter from the area.
- ❑ Manually rotate the compressor flywheel a few turns, in the proper direction, to assure that movement is free. For larger compressors, this may require a barring device, which will be supplied by PDC. Make sure the compressor is unloaded both on the process side, as well as the hydraulic oil side. The compressor flywheel will not rotate freely if either the process or oil side is loaded. If the movement is not free, determine the cause and take the appropriate corrective action.
- ❑ Fill the crankcase to the proper level with the appropriate lubricant. Lubricant type and approximate capacity can be found in the Compressor Specification Sheets or the Lubrication Schedule if included. The compressor design, environmental climate and the process fluid being compressed, define the type of oil to be used.

Warning: Failure to use the proper lubricant, or the proper amount of lubricant, can result in damage to the compressor equipment and risks injury to the operating personnel.

- ❑ Typically, oil is added through the air breather assembly located in the top of the crankcase. An oil level indication device is provided in the crankcase to determine proper fill levels. PDC 2 Series compressors have an oil dipstick for level determination. The dipstick hole is also used for oil filling.
- ❑ Replace the air breather assembly. Check to make sure the air breather assembly is free from obstructions and sources of contamination. Only clean air should be drawn through the breather assembly.
- ❑ Conduct a final inspection of the compressor, support equipment, service connections and safety devices.
- ❑ Check V—drive belts for proper tension and adjust if necessary. Observe sheaves for proper alignment. On smaller compressors, the belt guard may have to be removed to do this. On larger compressors a removable access plate is typically provided on the belt guard.

Operation (continued)

- ❑ Open isolation valves for the compressor cooling water service connections. Verify cooling water flow and check to be sure all cooling water interlocks (flow, temperature for cold environments, etc.) are working properly.
- ❑ Apply instrument air to the compressor system if required. Verify pressure level and capacity of the air service connected to the compressor.
- ❑ Review the unloading requirements for the compressor system and verify the necessary components are installed and operating. Unloading systems are not required for PDC 2 and most PDC 4 series compressors. Consult the Compressor Specifications Sheets for unloading system requirements.
- ❑ Open the relief valve bypass valves on the hydraulic oil system or systems depending on the number of compression stages. There will be one bypass valve per head assembly or stage of compression. This valve will be clearly tagged from the factory. There are (2) basic oil systems in a diaphragm compressor. One system is responsible for generating diaphragm displacement in the head, while the other is responsible for lubricating the compressor frame. Each stage of compression, or each head assembly, will have its own, dedicated, diaphragm displacement oil system, which includes the bypass valve. Each compressor frame, which may have one or more heads or compression stages, will have its own lubrication system. Review the "Hydraulic System Schematic" found in the drawing section of this manual for additional information
- ❑ Regardless of normal startup requirements, initial startup for oil side priming must be done with a reduced process pressure load. This is necessary because the hydraulic oil relief valve, or pressure control, is manually bypassed during priming which allows free oil flow and air removal. During oil priming, any process pressure load experienced by the compressor must be overcome by the oil system. Since the pressure control system is bypassed during priming, it is difficult for the oil system to overcome this load, therefore, making priming difficult. For oil priming, the compressor inlet and outlet can be opened to atmosphere, allowed to recycle from outlet to inlet or can have the inlet pressure regulated to a low pressure which will be pumped through the compressor at minimal boost conditions. Never block (or dead end) the inlet or outlet of the compressor.

Warning: The oil priming procedure is very critical to establishing proper compressor operation, as an improperly primed compressor will cause hydraulic system cavitation, shock loading and excessive vibration.

- ❑ When you are sure the compressor is properly configured for startup and oil priming mode, open the process fluid isolation valves.

Warning: Be sure all shutoff valves on the inlet and outlet side of the compressor are open prior to starting. Failure to do so may result in severe cavitation on the inlet and excessive pressure at the outlet, which may cause damage to the equipment and/or personal injury.

Operation (continued)

- ❑ Jog the compressor motor for a brief period. Check and verify the direction of rotation, reverse motor direction if required. A rotation direction arrow is located on the belt guard assembly. Typically, PDC Diaphragm compressors rotate clockwise facing the compressor from the flywheel side. Check to make sure all moving compressor components are moving freely without obstruction.

Warning: When starting the compressor, operate for only a few seconds and shut down prior to reaching full speed. Do this to insure that everything is moves freely without obstruction and allows the operator to check the direction of rotation. Operating the compressor in the wrong rotational direction will result in hydraulic system failure and cause damage to the compressor.

Warning: Never run the compressor with a suction pressure higher than the discharge. ALWAYS equalize the suction and discharge before starting the compressor. Failure to follow these procedures will result in extremely high gas velocities, high gas temperatures and damage to gas Check Valves.

Initial Start-up and Priming

- ❑ Start the compressor and allow it to accelerate to full speed. Listen carefully for any unusual noises, vibration or other abnormalities. Shut down the compressor immediately if you have any concerns. Allow the compressor to run and begin to circulate oil through the hydraulic systems. PDC 2, 3 and 4 Series compressors are splash-lubricated frames. PDC 5 through 13 Series compressors are pressure-lubricated frames via a hydraulic gear pump. All PDC compressors utilize a hydraulic gear pump to prime the inlet port of the injection pump. Please review the “Principles of Operation” section of this manual for additional information regarding the injection pump and other operational characteristics.
- ❑ For pressure lubricated frames, a pressure gauge and switch are provided to monitor and interlock the frame lubrication system. During startup, observe the pressure gauge to verify oil pressure is being generated. The pressure setting of the frame lubrication relief valve is found on the hydraulic system schematic. If pressure does not build in a timely manner (less than a minute) check the rotation direction of the compressor, oil level, or oil system for leaks or blockage. It is normal for this pressure level to decrease slightly as the oil warms up. This is due to the change in viscosity at higher temperatures. The compressor control circuit must incorporate a time delay of approximately 20 seconds to allow base oil pressure to build up during starting.
- ❑ For PDC 2, 3 and 4 series compressors (splash lubricated frames) an oil interlock system can be provided if the compressor is to be operated completely unattended for long periods of time. This will protect the compressor in the unlikely event of a ruptured oil line or oil leak that results in a serious loss of oil in the crankcase. Consult the factory for information regarding this option if you attend to operate completely unattended for long periods of time.

Warning: Failure to properly protect the compressor frame from inadequate lubrication will result in damage to the compressor.

Operation (continued)

- ❑ During initial startup procedures, constantly check and maintain the crankcase oil level. As the compressor runs, oil is pumped to the head assemblies until they are filled. For larger compressors, the head filling procedure can take up to an hour of starting, stopping and filling before the oil level is stable. It is possible to observe a difference in oil levels between the stopped and running conditions. Typically, the stopped condition will result in higher oil levels. Ultimately, the minimum correct oil level is a half filled indicator while the compressor is running properly.
- ❑ When the compressor heads are filled, oil will begin to flow in the sight flow indicator (sight glass) located downstream of the bypassed hydraulic relief valve. Typically, the sight glass flow is returned to the crankcase through the injection pump body assembly. This oil flow helps lubricate the cam found in the injection pump assembly. Depending on how the system is piped, (mainly based on how the trapped air in the tube lines is venting back to the crankcase) etc., the sight glass can run completely full or the oil can run down the side of the glass. If the glass is full, it is difficult to observe oil flow in the glass. Shinning a small light through the glass from the opposite side you are viewing, allows you to observe oil flow in a full sight glass. Initially, this oil flow will be foamy as it is mixed with air that is being displaced from the compressor heads. Over a period of time, the larger the head the longer the time period, this oil flow will clear up as the air is completely displaced and the heads are filled with oil. Once the heads are filled, a clear oil flow should be established in each sight glass.
- ❑ Once clear oil flow has been established in the sight glass for each head, close the oil relief valve bypass valve for each head. At this point, oil which was bypassing around the relief valve will be diverted to the relief valve inlet port. For a brief period, oil flow in the sight glass will stop. The injection pump will add oil during each revolution of the crankshaft. The pressure will begin to rise in the hydraulic system and the noise level of the compressor will increase as a result of the load on the compressor system. As the pressure in the hydraulic system reaches the relief valve setting, oil will once again begin to flow in the sight glass. Small amounts of residual air that was trapped in the oil system will cause foamy oil characteristics for a brief period of time, however, a clear oil flow should be reestablished in a few minutes. Once the compressor has established clear oil flow in the sight glasses for several minutes with the relief valve bypass valves closed (indicating the compressor is fully primed), the compressor is ready to be loaded from the process side.

Warning: The hydraulic relief valve pressure setting has been factory set. Do not adjust, or tamper with the relief valve setting unless you have a thorough understanding of dynamically setting hydraulic relief valves. Information regarding the dynamic setting of relief valves can be found in the “Maintenance” section of this manual. The improper setting of the hydraulic relief may result in damage to equipment and/or injury to personnel.

Operation (continued)

Warning: Failure to assure the compressor is fully primed, prior to pumping process fluid, will result in poor compressor performance and may cause damage to the equipment.

- ❑ Place the unloading system of the compressor in the loaded position, which will result in process fluid media being introduced to the compressor inlet and outlet. For compressors not using an unloading system and were primed with a reduced process load as discussed above, return the process load to normal conditions. Provided the compressor outlet is connected to a restricted source or some pressure control device, the pressure at the compressor outlet will initially balance with the inlet pressure and then begin to increase as the compressor pumps gas. Outlet pressure will continue to increase until the pressure control system either shuts the compressor off at the desired pressure or the pressure control system diverts flow to back to the inlet or to another area of need.
- ❑ While the compressor is running, verify that all control, support and safety systems are functioning correctly and that the compressor is operating within its specified parameters. Monitor inter-stage temperatures and pressures to verify fitness and function of the compressor system. Check the current being drawn by the motor. Check and verify lubricant levels. Check V-drive belt tension. Observe all piping systems for leakage. Allow the compressor to run for a few hours while operation is carefully monitored. Recheck all systems for fitness and function prior to placing the compressor into final operation.

Shutting Down the Compressor

- ❑ Unload the compressor and then shut the compressor motor off. If you are not using an unloading system, shut the motor off.
- ❑ Cooling water should be run through the compressor for approximately 15 minutes after the compressor is shut down.

Compressor Priming Requirements

Compressors require priming whenever circumstances related to the most recent shut down allowed for oil loss in the heads or it is being started for the first time. Oil loss can occur from leaks, maintenance procedures, thermal contraction of the oil in the heads, opening of the oil relief valve bypass valve by the operator, sitting for periods of in excess of one week, etc. For any of the above reasons, the priming sequence must be repeated prior to placing a process load on the compressor. Compressors shipped from the factory are fully primed, however, may require re-priming during initial startup.

Operation (continued)

Restarting the Compressor

For starts **not requiring** priming:

- Re-establish cooling water flow.
- Verify the compressor is unloaded and start the motor. Allow the compressor to accelerate to operating speed. For compressors not using an unloading system, start the motor. After 20 seconds, set the process system to the loaded position. Observe compressor operation for abnormal conditions. Once the compressor has been successfully started and stopped several times, subsequent starting and stopping can be done unattended.

For starts **requiring** priming, follow the above procedure for “Initial Start-up and Priming”.

Warning: Starting the compressor when it is not fully primed will result in poor compressor performance, cavitations and may result in damage to the equipment.

Normal Compressor Operation

Once the compressor has been successfully started, the compressor should continue operate normally until it is shut down. The type of process being run and the piping/control system, which has been provided, typically defines normal compressor operation requirements. Refer to the “Process Schematic” or P and ID for information about the systems and components provided.

Warning: Never operate the compressor outside the design parameters specified in the “Compressor Specification Sheets” found in this manual.

Back-up Compressor Operation

Many compressor systems utilize (2) compressors to achieve zero downtime attributed to maintenance, unexpected shutdown, etc. If the on-line compressor shuts down, the back-up compressor starts and takes over.

In order for the back-up compressor to start and take over, it must be properly primed and ready to start. It is necessary to run the back-up unit on regular basis to assure it is fit and primed. For continuous operation, it is recommended the back-up unit be run at least once a day (either unloaded or with a reduced process pressure load as mentioned above) in order to assure its readiness. The duration of this run should be long enough to assure the compressor is fully primed as defined above, typically about (10) minutes.

Operation (continued)**Standard Operating Procedures**

It is the user's responsibility to develop a sight specific "Standard Operating Procedure", or SOP, for each compressor installation. This procedure should cover compressor operation, maintenance and any sight specific requirements that apply to the compressor installation. Start-up, shut down, service interlocks, equipment isolation, lock out/tag out procedures, all should be included in this procedure. This procedure is necessary to assure the compressors' safe and proper operation by all personnel using it. If requested, PDC will review and comment on your SOP with respect to compressor considerations.

Maintenance

Safety Precautions

Before and during any maintenance work being performed on the compressor or any of its support equipment, be absolutely sure the following precautions and safety rules are observed:

- ❑ Properly shut down the compressor. Allow hot components to cool prior to proceeding with maintenance.
- ❑ Isolate the compressor from all main service connections such as electrical, process, cooling water, instrument air, etc. Lock-out/tag-out procedures should be used to prevent the services from being accidentally restored.
- ❑ Vent residual pressure from all piping, compressor heads, etc.
- ❑ Always use the proper tools and other equipment to perform maintenance.
- ❑ Never place your hand or arm inside the crankcase without realizing the crankshaft can rotate unless it has been mechanically secured.
- ❑ After any maintenance, carefully observe the compressor for a period of time necessary to assure the compressor is operating normally.

Cleaning and Lubricating

It is important during maintenance activities that all parts be thoroughly cleaned, particularly oil passages, seal surfaces, etc. Where permitted generously lubricate parts as they are reassembled.

Note: When replacing any parts in the compressor system, use only high quality replacement parts supplied by PDC Machines, The use of any other replacement parts will void the warranty.

Maintenance (continued)

Daily Maintenance Check List

- Lubricant oil level. Add as required.
- Base frame lube pressure for PDC Series 5 through 13 compressors.
- Cooling water flow, temperature and pressure.
- Operation of control systems.
- Inlet filter pressure drop.
- Drain separator tanks.
- Verify inlet, inter-stage and outlet pressures are in order.
- Check for abnormal noise or vibration.
- Check the leak detection systems on all heads.

The above items should be checked at least once a day. It is not good practice to leave reciprocating machinery run unattended over prolonged periods of time. For units operating 24 hours a day, the above items should be checked every 8 hours. A logbook should be maintained to record equipment inspections and maintenance activities as they are performed.

Inlet Filter

The inlet filter should be disassembled and inspected every 300 hours of operation. Replace or clean the element as required. If the compressor system is equipped with an external filter-monitoring device such as a differential pressure gauge or transmitter, disassembly and inspection may not be necessary. If regular inspections at 300 hour intervals reveal excessively dirty elements, inspection frequency should be increased.

Some systems are equipped with dual filter systems for servicing one filter while the other remains on-line. This option is supplied with the appropriate isolation and venting valves. Isolate and vent pressure on the filter that requires maintenance. Always make sure to verify the alternate filter is on line prior to isolating the other filter. Process P and ID show the process system and its components. Sizing of the inlet filter is discussed in the Section 3, Installation, Process Piping Connections.

Warning: Never isolate both filters of a dual element system. This will dead end the compressor and result in damage to the equipment and possible injury to personnel. The SOP should carefully detail this procedure. Lock and tag valves as required.

Maintenance (continued)

Lubrication Systems

PDC 2, 3 and 4 Series compressors are splash-lubricated power frames. A slinger mechanism is attached to the crankshaft and splashes oil throughout the crankcase as it rotates. The oil level in this style power frame is critical and must be carefully maintained. A sight glass on the side of the crankcase is provided to monitor oil level. Do not over or under fill the crankcase. Oil level in the sight glass MUST be at least $\frac{1}{2}$ to $\frac{3}{4}$ full when the compressor is running normally.

Warning: Never overfill the crankcase. This will result in aeration of the oil, resulting in cavitations and potential damage to the compressor.

PDC 5 through 13 Series compressors are pressure-lubricated power frames. The crankshaft drives a hydraulic gear pump, which provides pressurized oil to points requiring lubrication throughout the power frame. A relief valve in the circuit controls oil pressure. The oil pressure settings for your compressor can be found in the "Hydraulic Schematic" found in this manual. Typically, the crankshaft, connecting rods, wrist pin, crosshead and bearing housings have drilled passages to allow oil flow in these areas.

In either style power frame, splash or pressure lubricated, a hydraulic gear pump is used to prime the inlet port of the injection pump. The crankshaft drives the gear pump. In the case of the pressure lube power frame, the gear pump is sized to prime the injection pump as well as lubricate the frame. Oil is drawn up from the crankcase lubricant sump, through a lubricant strainer to the inlet of the hydraulic oil pump. Oil from the outlet of the pump is then forced through a filter, and then diverted to the injection pump inlets and other lubrication points in the power frame if it is pressure lubricated. The relief valve setting controls pump outlet pressure. Oil displaced by the relief valve is returned to the crankcase sump.

The following items need to be addressed during maintenance of the lubrication system:

- ❑ Crankcase Sump Oil – Drain and replace. Wipe the sump clean of any foreign particles. Inspect any foreign particles removed as they may indicate wear in other areas of the compressor. Replacement oil information can be found in the "Compressor Specification or Data Sheets" found in this manual. Typically, hydraulic oils used have the recommended viscosity, are of high quality, refined by a reputable oil company, contain anti-oxidation, anti-foam additives, have high chemical stability and adequate film strength. Oil is added through the breather port with the breather removed.
- ❑ Strainer – Remove screen element. Clean or replace as required.
- ❑ Filter Element – Remove element and replace. Fill element and/or housing with oil during reassembly. This will reduce the time components do not receive lubricant during the subsequent start-up. Inspect gaskets and seal rings in the filter housings, replace as required.
- ❑ Crankcase Breathers – Remove and inspect, replace as required.

Maintenance (continued)**Frequency of Lubrication System Maintenance**

- ❑ Change oil and oil filter elements after 50 hours of initial operation. Clean or replace strainer element as required.
- ❑ Change oil and oil filter elements after every 1500 hours of subsequent operation. Clean and replace strainer element.
- ❑ Change oil and oil filters elements immediately if the oil viewed in the sight glass is abnormally discolored.

Maintain a logbook for all maintenance activities.

Warning: The use of oils, other than those supplied by PDC, must be approved by PDC. Fax the data sheet from the oil you propose to use to PDC for review and approval.

Warning: Failure to maintain the lubrication systems on a regular basis will result in premature component failure and poor compressor performance.

Warning: Highly explosive or unstable process fluid media may require fire resistant oil. Consult the factory for recommendations.

Maintenance (continued)

Diaphragm and O-Ring Seal Replacement

- ❑ Isolate the compressor from all main service connections such as electrical, process, cooling water, instrument air, etc. Lock-out/tag-out procedures should be used to prevent the services from being accidentally restored.
- ❑ Vent residual pressure from all piping, compressor heads, etc.

Warning: Failure to properly isolate and vent the compressor will result in serious injury to personnel.

Review the “Head Assembly” drawing and associated “Bill of Material” found in the appropriate section of this manual. The “Head Assembly” drawing shows a cross sectional view of the head assembly and calls out the various items. Assembly notes, bolt torques, etc. are given on the drawing. The “Bill of Material” lists the individual items along with each items respective part number, description, material of construction and size.

Note: Never replace diaphragms without replacing O-Ring seals at the same time or vice versa.

Remove cooling water and process piping that will interfere with head removal. Process check valves and their retainers can be left in place if desired; however, since the head is apart, it is recommended they be inspected.

Depending on the design of the head assembly, it may be desirable to drain the oil from the heads, especially for larger head assemblies. For smaller compressors, the volume of oil in the head does not warrant a draining system and can be handled with rags and small trays. The head assembly drawing shows the location and size of plugged drain ports. Typically there will be one port at the bottom and some means for venting air at the top. Place a container under the bottom drain port. Remove the plugs and allow the oil to drain. Replace all plugs and remove containers once the oil has drained.

Arrange for the proper lifting mechanism to lift the process head. Mark the head assembly accordingly to shown orientation during reassembly. Secure the process head with the lifting device. The compressor heads are provided with tapped holes for lifting purposes. The user supplies lift eyes, bolts, chains, straps, etc. Loosen head bolts. Adjust the lifting mechanism so that it is taking the weight of the head prior to removing bolts. Remove bolts. Lift and move the head away from the compressor to an area where it can be cleaned and prepared for reassembly.

Maintenance (continued)

Diaphragm and O-Ring Seal Replacement (continued)

The diaphragm set is sandwiched between the process head (just removed) and the lower head. There are (3) diaphragms in the set and they are held in place by a series of cap screws around the perimeter. Remove the cap screws. Carefully hold the diaphragms around the edges and remove the used diaphragm set.

Warning: Diaphragms are made from thin sheet metal and have very sharp edges. Exercise caution when handling diaphragms to prevent cutting your hands and fingers.

There are (3) O-Ring seals, (1) in the face of the process head and (2) in the face of the lower head. Carefully remove the used O-Rings.

Using clean solvent and rags, wipe the face of both heads clean. Carefully wipe the O-Rings grooves clean. Deposits that will not wipe off can be polished with 600 grit sandpaper until removed. Score marks can be polished until they are flush or below the cavity surface. Final cleaning of the process head should be done with a cleaner that will not contaminate the process fluid media.

Remove the replacement Oil O-Ring from the plastic bag in which it is packed. Wipe a very thin coating of lubricant (usually vacuum grease) on the O-Ring. Place it in the Oil groove, which is the smaller (innermost) of the (2) grooves in the lower head. It may be necessary to stretch the O-Ring in order to make it fit in the groove. The lubricant will help hold it in place.

Verify the diaphragm material, as marked on the package, is consistent with the compressor's material of construction and the "Bill of Materials". Remove the replacement diaphragm set from its packaging. Replacement diaphragm sets from PDC are cleaned and ready for installation, however, check to make sure the diaphragm set has remained clean during shipping and is suitable for your application. Diaphragms sets have two stainless steel (or other materials) disks at the top and bottom separated by a brass disk in the middle.

Place the diaphragm set over top of the Oil O-Ring onto the face of the lower head. Secure the set in place with the screws previously removed. Check to be sure that the diaphragm set fits between the body of the attachment screws with a small amount of clearance and is held in place with the heads portion of the screws. Attachment screws do not have to be torqued, as they simply hold the diaphragm set in place during assembly. Over tightening these screws will damage the diaphragms.

Remove the replacement Leak Detection O-Ring from the plastic bag in which it is packed. Wipe a very thin coating of lubricant (usually vacuum grease) on the O-Ring. Place it in the Leak Detection groove, which is the larger (outermost) of the (2) grooves in the lower head. It may be necessary to stretch the O-Ring in order to make it fit in the groove. The lubricant will help hold it in place.

Maintenance (continued)

Diaphragm and O-Ring Seal Replacement (continued)

Remove the replacement Process O-Ring from the plastic bag in which it is packed. Wipe a very thin coating of lubricant (usually vacuum grease) on the O-Ring. Place it in the Process groove, which is in the process head. It may be necessary to stretch the O-Ring in order to make it fit in the groove. The lubricant will help hold it in place.

Position the process head in front of the lower head in the same position it was in prior to being removed. Note the markings from earlier in the procedure. Line up the bolt holes. Replace the bolts in the head assembly. Snug bolts by hand. Look between the process and lower heads to make sure that all the O-Rings and diaphragms have remained properly positioned. Tighten the bolts in increments of 25% of the final torque value specified on the drawing. The tightening sequence is stamped on the head. Verify that the final torque value has been obtained on all the head bolts. Do not apply 100% of the specified torque in one step.

Warning: Failure to tighten bolts properly will result in damage to the equipment and personnel injury.

Replace check valves and retainers if removed, torque retainers as specified on the drawing. Replace the cooling water and process piping which was previously removed.

Follow procedures for "Initial Startup and Priming" found in the "Operation" section of this manual.

Maintenance (continued)

Process Check Valves

Each head assembly has inlet and outlet check valves for the process stream. These valves are very critical to proper compressor operation. Faulty valves will seriously degrade the compressor performance. Process check valves should be inspected after every 4,000 hours of operation.

There are (2) basic types of process check valves used in PDC diaphragm compressors. The smaller valves are cartridge style valves whereas the larger valves are flat disc poppet style type. Refer to the "Illustration" section for typical exploded views of these valves.

Review the "Check Valve Assembly" drawing and associated "Bill of Material" found in the appropriate section of this manual. The "Check Valve Assembly" drawing shows a cross sectional view of the valve assembly and calls out the various items. Assembly notes, instructions, etc. are given on the drawing. The "Bill of Material" lists the individual items along with each item's respective part number, description, material of construction and size.

Check valves are held in place by retainer plates or nuts, which are itemized on the associated "Head Assembly" drawing. Details for retainer assembly, valve orientation, retainer torque, etc. are also found on the "Head Assembly" drawing.

Cartridge style check valves use a press fit spring retainer in the outlet side of the check valve to hold the poppet and spring in place for assembly. This retainer has a radial slot so it can be spread open to achieve an appropriate press fit into the cage. Only enough interference to hold the retainer in place is necessary. To disassemble a cartridge check valve, push on the face of the poppet from the inlet side of the valve (through the flow orifice). Use caution and an appropriate pushing device, so as not to damage the poppet face. Lightly tap the poppet until the retainer is dislodged from the other side of the valve. Be sure to not to lose the retainer and spring as the valve is disassembled.

At the user's discretion, worn valves can be replaced completely, or rebuilt with new poppets, seals and springs.

Make sure all replacement valves are thoroughly cleaned in an appropriate manner prior to putting them in service. Verify that all seals and gaskets have been reassembled.

Oil Inlet Check Valves

The oil inlet check valve should be disassembled and checked every 4,000 hours. Inspect the O-ring seal and mating seal surface for signs of wear. Replace if worn.

Maintenance (continued)

Hydraulic Oil Relief Valve

The hydraulic oil relief valve is very critical to proper compressor operation. This valve limits the oil pressure in the compressor system and opens at top dead center of every crankshaft revolution. The seat area of the oil relief valve is subjected to very high fluid velocities and as a result erosion and wear are concerns. The seat area design and materials of construction have been carefully selected to withstand this environment. The relief valve seat should be inspected at least once every 4,000 hours of operation.

Two styles of oil relief valves are used. For pressures below 1,000 psig, an internally adjustable, cartridge style relief valve is used. For pressures in excess of 1,000 psig, a custom fabricated, externally adjustable valve is used. An assembly drawing and bill of material is provided for the custom fabricated valves.

Disassemble the valves, inspect the seat and repair as required, or replace them entirely. Reassemble the valve. Install the valve on the compressor. Follow the dynamic setting procedure below.

Warning: Statically bench set relief valves will run at significantly higher pressures in the dynamic compressor environment.

Relief valves should be ordered set from the factory. Be sure to specify the set pressure when an order is placed with PDC. The set pressure can be found in this manual, or on the tag attached to the relief valve. Factory set relief valves are **always** marked as such. Never assume a valve is set if it is not marked.

Warning: Never operate a compressor with a hydraulic oil relief valve set dynamically above its design pressure. Damage to equipment and/or injury to personnel are likely to occur.

Maintenance (continued)

Hydraulic Oil Relief Valves

Hydraulic oil relief valves must be set dynamically on the compressor while it is running. Before the compressor is shipped, hydraulic oil relief valves are set at the specified pressure and marked accordingly. Spare part relief valves are not factory set and must be set in the field.

PDC uses two styles of relief valves. For pressures up to and including 600 psig, an internally adjusted, soft-seated relief valve is used. For pressures over 600 psig, a metal-seated valve, manufactured by PDC is used. The low-pressure valve is listed on the hydraulic system bill of material and is typically replaced in its entirety when necessary. For the high-pressure valve, a drawing and bill of material can be found in the manual for use in assembly/disassembly and maintenance purposes.

Setting the Hydraulic Oil Relief Valve

Install the valve on the compressor. Back off the adjustment nut (turn counter clockwise facing the nut) until you can feel the load or force from the internal spring release from the nut. In this position, the valve will hold no pressure. From this point, turn the nut clockwise 2 turns. This will keep the internal parts in position during setting.

Install the "Piping required to set relief valve dynamically" as shown in drawing A0020004 found in Section 7 of this manual. This piping consists of a gauge, check valve and vent valve. The check valve isolates the gauge and vent valve from pressures lower than what has already been trapped or in other words the gauge only reads the peaks or relief valve setting. The vent valve allows the operator to vent pressure and recheck the setting.

Start the compressor using the start-up procedures found in this manual.

Turn the valve adjustment nut clockwise to increase pressure setting, which should be followed by an increase in pressure as shown on the gauge. Do not turn the nut more than ½ turn per adjustment. Continue to adjust the nut until the specified setting is reached. For the low-pressure series of valves, the top section of the valve must be removed to make setting adjustments.

Check the setting several times after the valve has been set to assure setting. As the compressor warms up, the oil viscosity changes and the setting will change. The final valve setting should be determined with the compressor running warm at the actual process conditions.

Once the valve has been properly set, tag the valve accordingly and set the locking collar for the high-pressure valve.

Maintenance (continued)

Compressor Base or Crankcase, Injection Pump and Head Assembly

For each of these items, an assembly drawing and associated bill of material has been provided. The assembly drawings show a cross sectional view of the appropriate assembly and calls out the various items. Assembly notes, instructions, fastener torque, etc. are given on the drawing. The "Bill of Material" lists the individual items along with each items respective part number, description, material of construction and size.

Warning: After every disassembly of any component thoroughly clean all the items. Before assembly lubricate all threads with acceptable anti-seize lubricant. For any threads coming in contact with process gasses ONLY use compatible lubricants for the applicable gases.

Compressor Base Oil reservoir Volumes

Following are the volumes of all the typical compressor frames used by PDC. These are volumes for just the crankcase. Keep additional oil on hand to accommodate volumes in the head assemblies.

PDC Crankcase	Oil Volume, US Quarts / Gallons	Oil Volume, Liters
PDC-3	3 Quarts / 0.75 Gal	2.84 L
PDC-4	7.5 Quarts / 1.85 Gal	7.0 L
PDC-5	4 Gal	15.14 L
PDC-8	4 Gal	15.14 L
PDC-13	9 Gal	34.07 L

Crankcase Oil Cross Reference List

1. Royal Purple Limited – Standard Oil supplied by PDC
 - Poly-Guard® FDA Synthetic hydraulic fluid
 - ISO Grade 68 AW***
2. Castrol Oil Company (formerly Drydene Oil Co.)
 - Paradene AW series hydraulic fluid
 - ISO Grade 68 AW***
3. Arco Oil Company
 - DU20 AW series hydraulic fluid
 - ISO Grade 68 AW***
4. Exxon Oil Company
 - NUTO H series hydraulic fluid
 - ISO Grade 68 AW***
5. Mobil Oil Company
 - DTE 20 series hydraulic fluid or DTE 10 Excel Series
 - ISO Grade 68 AW***
6. Shell Oil Company
 - Tellus series hydraulic fluid
 - ISO Grade 68 AW***
7. General Oil Description
 - Premium quality, thermally stable, anti-wear hydraulic fluid with rust / oxidation inhibitors and anti-foam additives. ISO Grade 68 AW. ***
8. American Chemical Technologies / Shell
 - SafetyFluid FR series fluids / Eco Safe S3
 - FR-68 and FR-100. ***

**** IMPORTANT ****

PDC uses Mobil® DTE 10 Excel Series (68AW) Oil in the crankcase. If any of the above recommended oils need to be used, flush the oil from crankcase and the heads with the above oils before using any of the recommended Oils.

*****IMPORTANT*****

ISO Grade 68 AW is used in all PDC-3 and PDC-4 compressors. ISO Grade 100 AW shall be used in all PDC-8 and PDC-13 compressors which utilize a lap-fit plunger, typically on compressors with discharge pressures greater than 3500 psig. **Consult the compressor specification sheet for which oil is specific to your machine.**

Lubricants for Assembly

Process O-rings			
Gas Type	Type	Make	Name
Hydrogen	Lubricant	Loctite	No. 2970 Krytox or DuPont MolyKote HP-870
Oxygen	Lubricant	Loctite	No. 2970 Krytox
Other Gases	Lubricant	Dow Corning	High Vacuum Grease DC-150

Pipe Thread			
Gas / Application	Type	Make	Name
Hydrogen	Lubricant	Dow Corning	High Vacuum Grease
Oxygen	Lubricant	Loctite	No. 2970 Krytox
Other Gases	Lubricant	Dow Corning	High Vacuum Grease
Air/Coolant, Line	Lubricant	Loctite	No. 567
MP and HP Fitting	Lubricant	Loctite, Swagelok	LB 771, LB8150 or Silver Goop(MS-TL-SGT)
Other NPT Threads	Lubricant	Loctite, Swagelok	LB 771, LB8150 or Silver Goop(MS-TL-SGT)
All Lines-NPT and Swagelok	Tape	Loctite	PTFE Pipe Thread Tape*

Bolt Lubricant			
Application	Type	Make	Name
Superbolts	Lubricant	SUPERBOLT	Type JLG
Other Fasteners	Lubricant	Loctite, Swagelok	LB 771, LB8150 or Silver Goop(MS-TL-SGT)

Maintenance Schedule Matrix

<i>Maintenance Function</i>	<i>Daily</i>	<i>First 150 hours</i>	<i>Every 300 hours</i>	<i>Every 1,500 hours</i>	<i>Every 4,000 hours</i>
Lube Oil Levels	*				
Lube Oil Pressure	*				
Cooling Water Flow, Temperature and Pressure	*				
Abnormal Noise or Vibration	*				
Motor Load	*				
Control System Functionality	*				
Instrumentation Functionality	*				
Leak Detection System Status	*				
Initial Oil and Oil Filter Change, Inspect Oil Strainer		First 50 Hrs.			
Initial Process Inlet Filter			*		
Regular Oil and Oil Filter Change, Inspect Oil Strainer				*	
Diaphragms and Diaphragm O-Ring Seals					*
Process Check Valves 1st and 2nd Stage					*
Oil Inlet Check Valve					*
Oil Relief Valve					*
Normal Process Inlet Filter					*
Inspect Crankcase Assembly					*
Inspect Compressor Lower Head					*
Inspect Injection Pump Assembly					*
Fuses					*
Control System Functionality					*
Instrumentation Functionality					*

Troubleshooting

Below is a list of potential problems, causes and corrective actions to be taken:

<u>Problem</u>	<u>Cause</u>	<u>Corrective Action</u>
Loss of prime, cavitation, excessive noise or vibration	Check oil level and pressure	Add oil to reservoir sump
	Oil relief valve bypass valve open under process load	Close valve and prime
	Worn, leaky oil relief valve	Replace and reset
	Leakage past main plunger, plunger seal rings, etc.	Disassemble and inspect Replace and repair as required
	Poor over-pump or injection pump flow	Adjust injection pump sleeve for max flow. Disassemble and inspect, repair or replace as required
	Oil relief valve set too low.	Check setting and adjust as required
Decrease in flow or pressure	Clogged or blocked line from reservoir to injection pump	Inspect line, strainer, filter, fittings, etc.
	Loss of prime	See above
	Process check valves leaking	Inspect process check valves. repair or replace as required
	Excessive pressure drop	Lines and or piping components to small. Replace with properly sized equipment
	Piping leaks	Vent down pressure and repair any leaks
Inlet line gets hot	Inlet check valve leaking back	Vent down pressure and repair
Leak detection system	Diaphragm or head seal failure	Disassemble heads, replace
Motor overload	Suction pressure to high	Reduce suction pressure

Drawings

Drawing A0020001 – Hydraulic Pressure versus Crank Angle Curve

CRANK ANGLE – PRESSURE CURVE

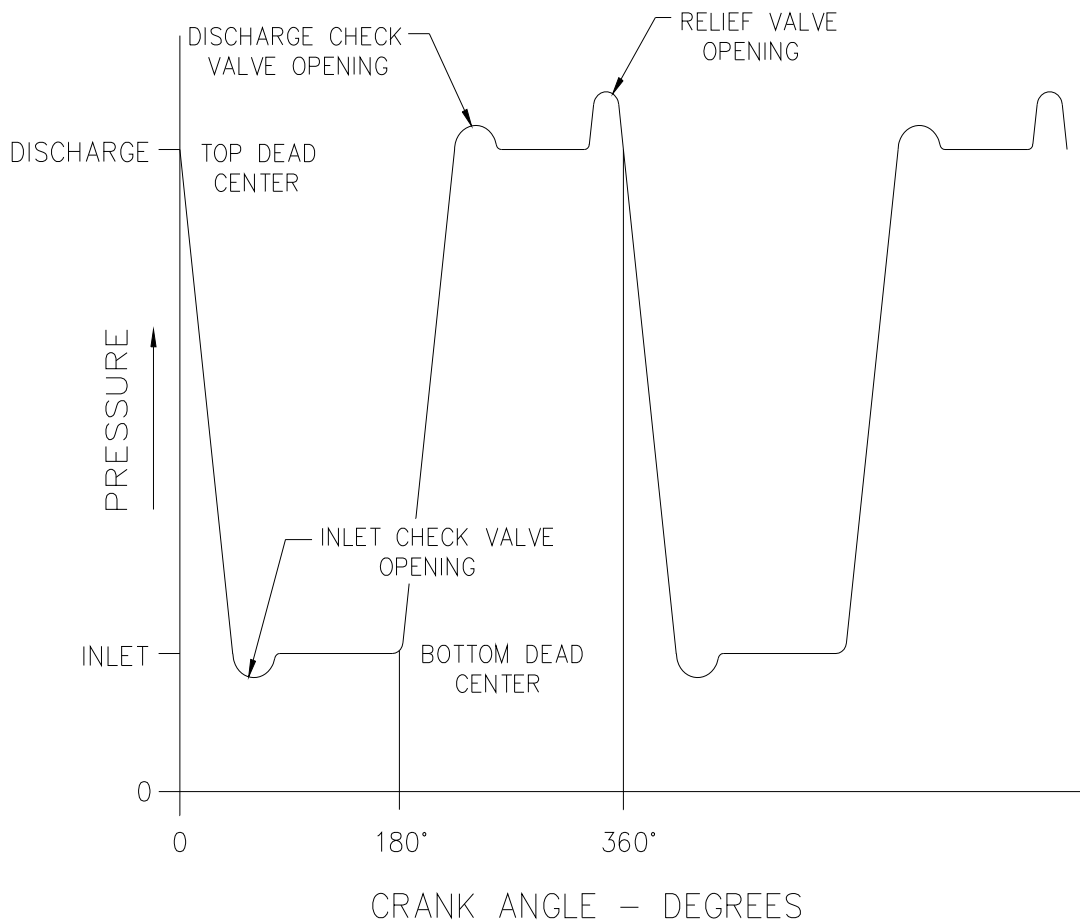

Drawing A0020002 – Basic Compressor Components

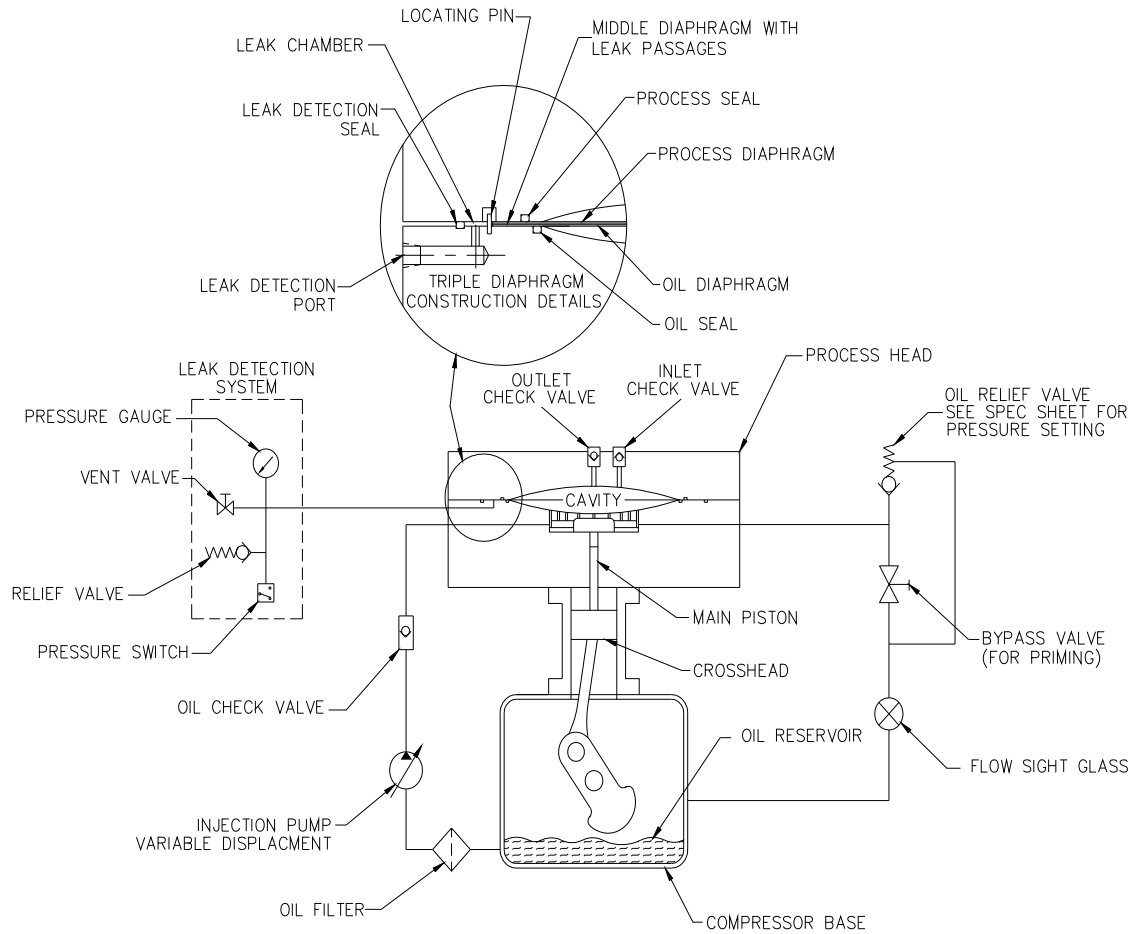

Drawing A0020004 – Compressor Accessories

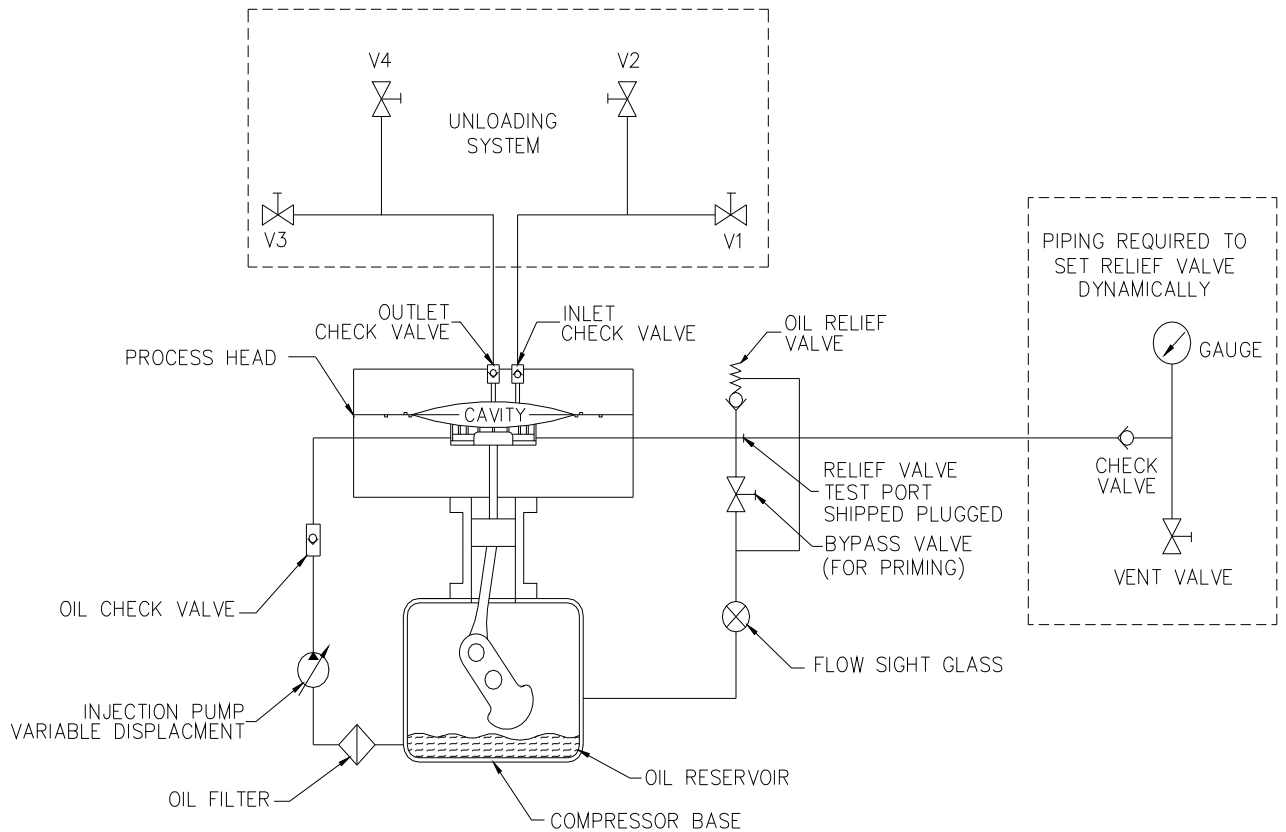

Foundation Figures

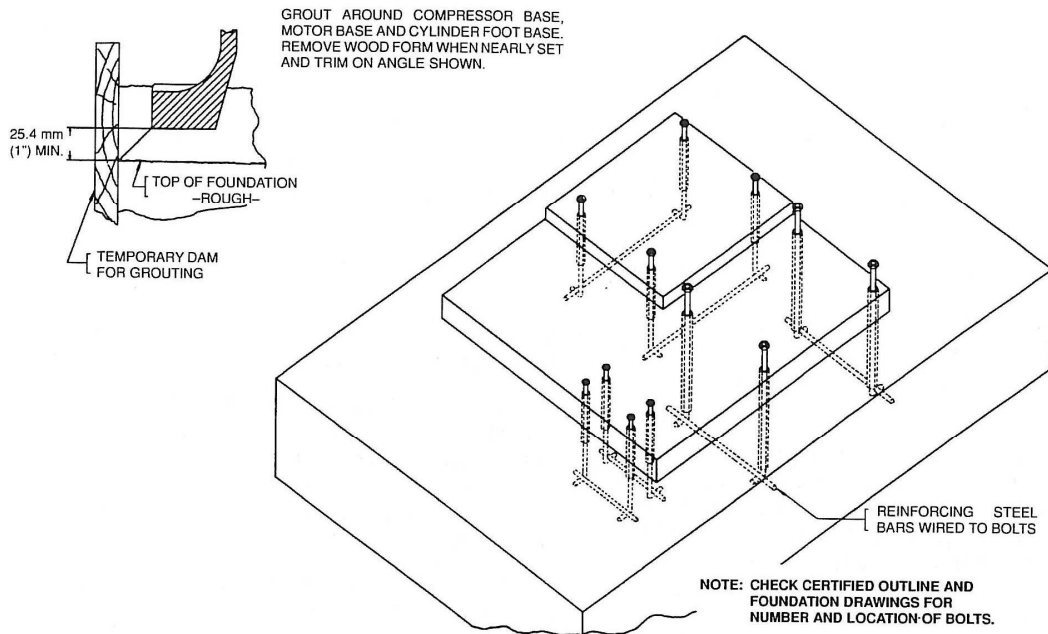

FIGURE 1-1 – TYPICAL FOUNDATION WHEN COMPRESSOR IS MOUNTED DIRECTLY ON FOUNDATION

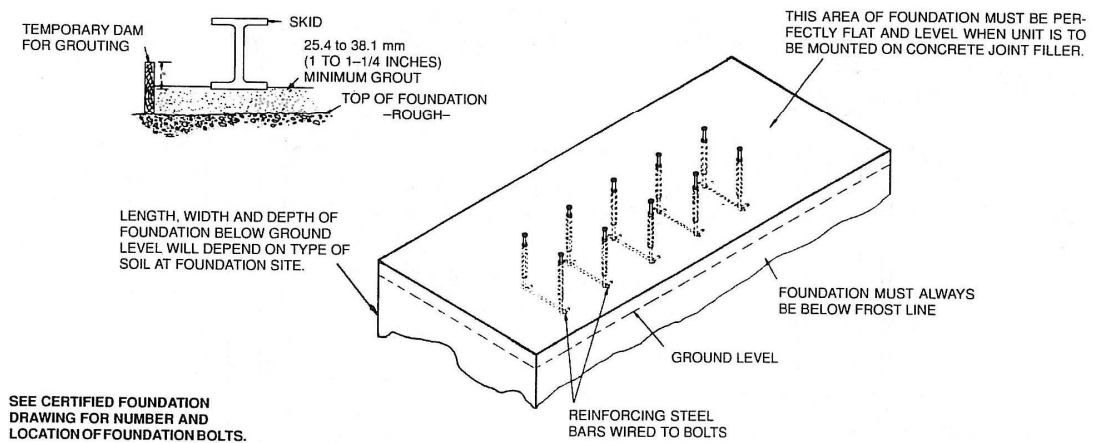

FIGURE 1-2 – TYPICAL FOUNDATION WHEN COMPRESSOR IS MOUNTED ON A STEEL BASE OR SKID

Foundation Figures- (Continued)

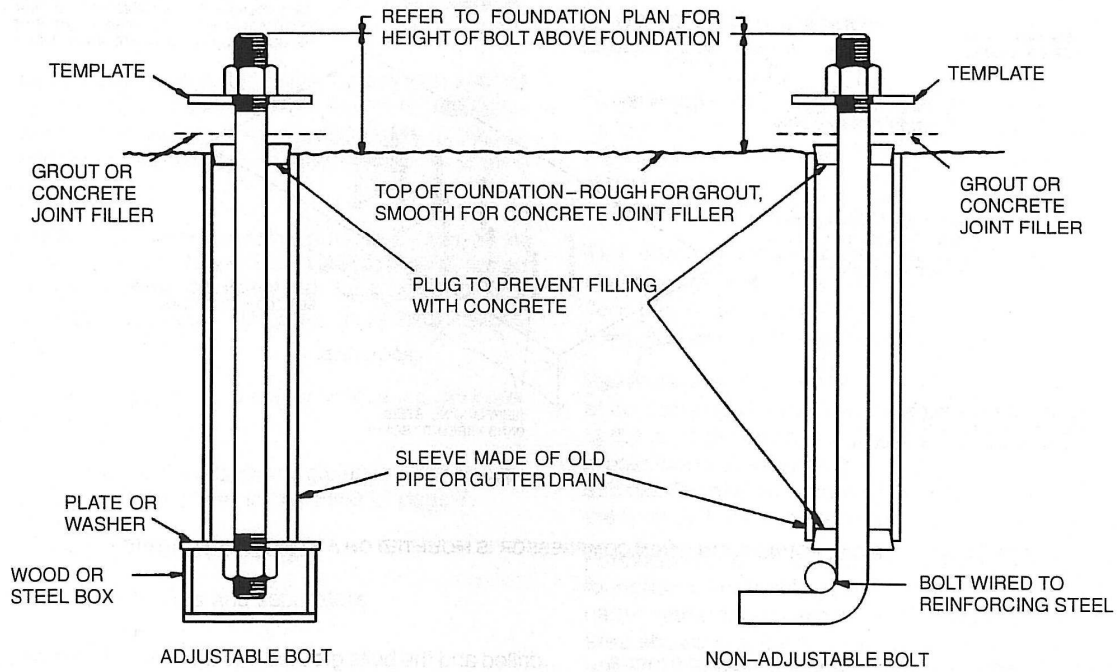
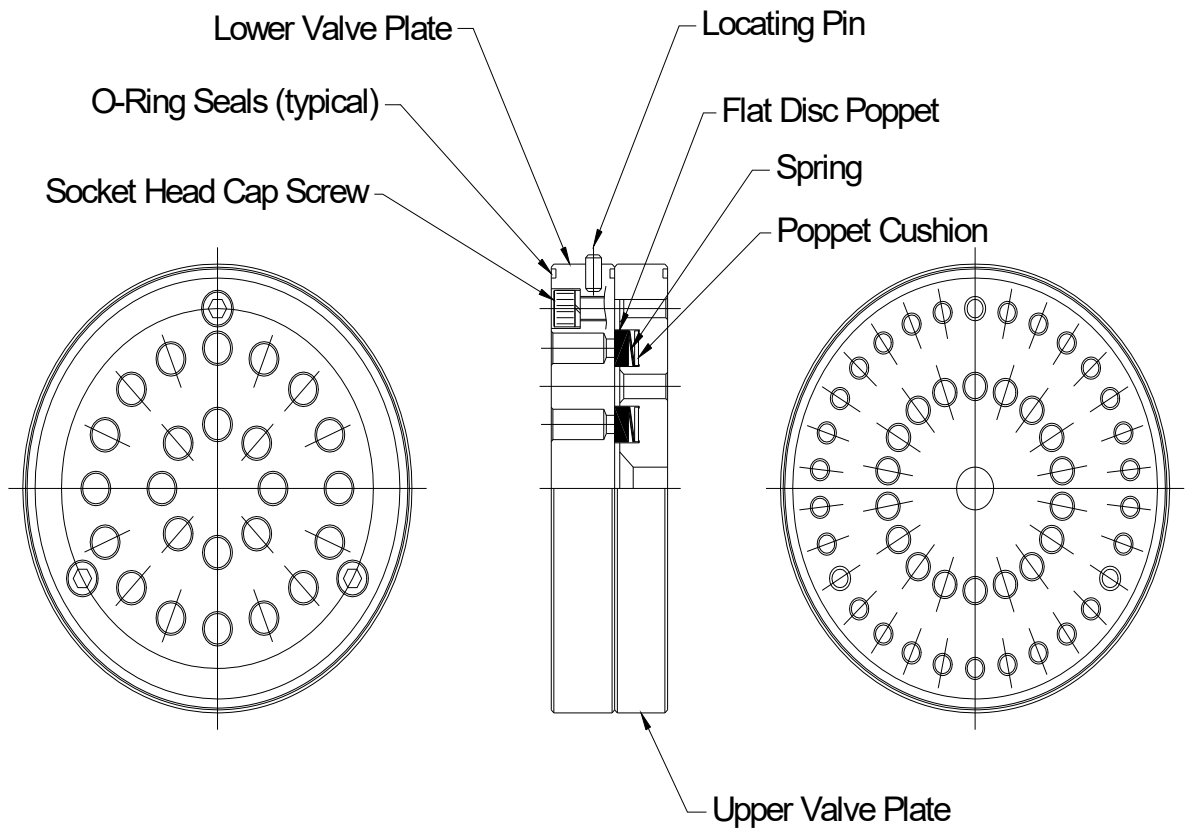

FIGURE 1-3 - FOUNDATION BOLTS

Flat Disc Check Valves



Flat Disc Check Valves

Exploded
View

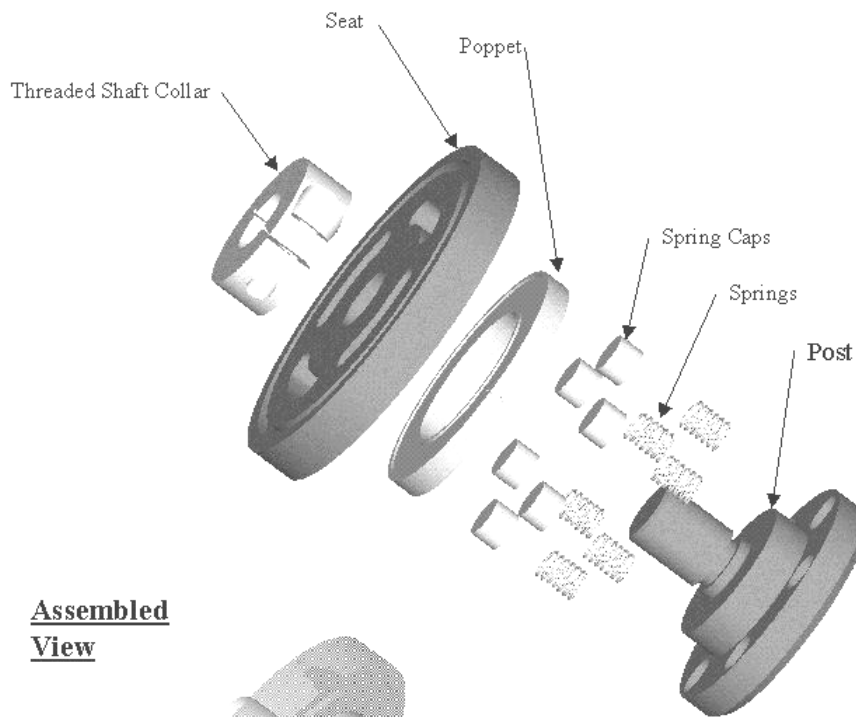

Assembled
View



Cartridge Check Valves

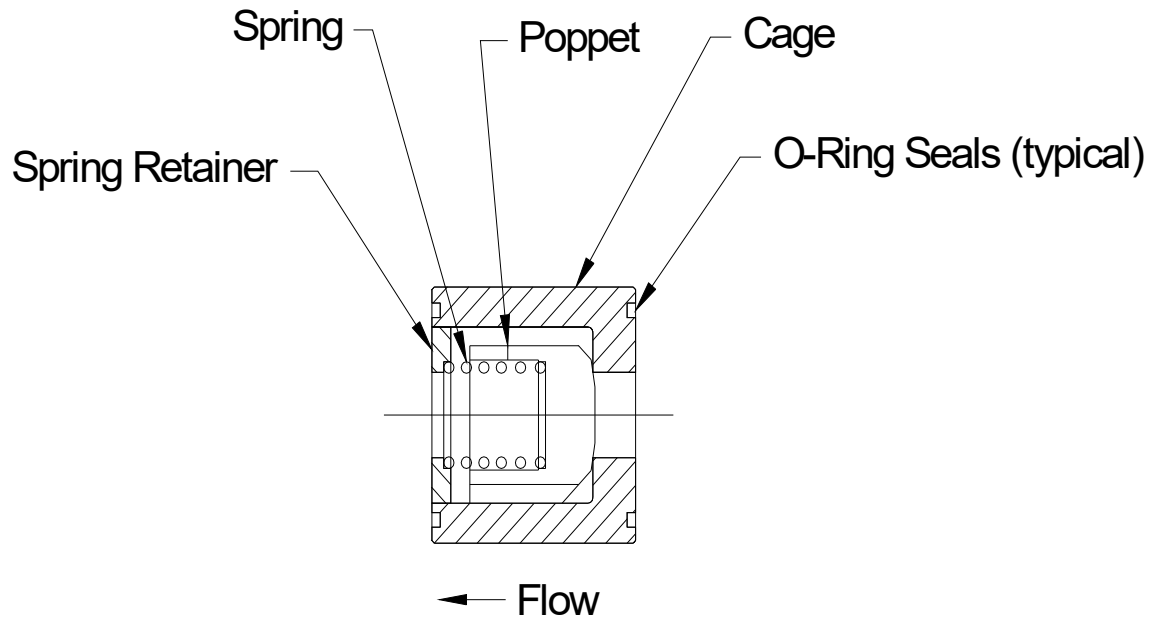

Cartridge Check Valves

Exploded View

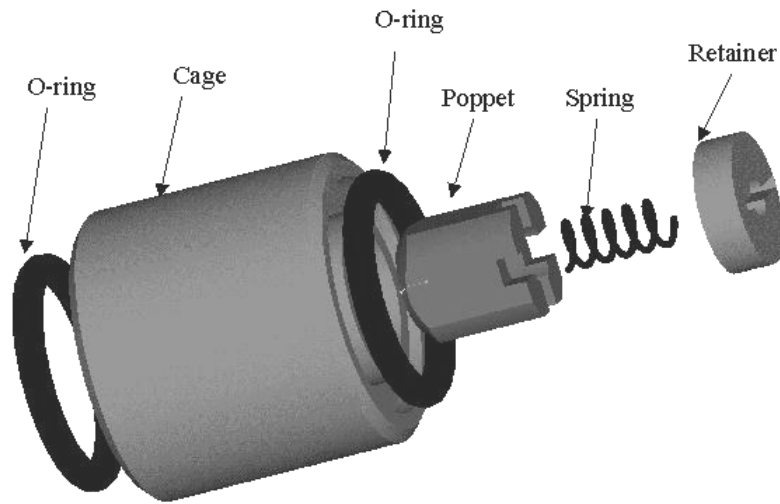

Assembled View

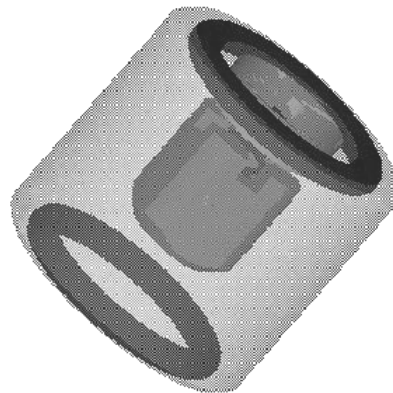

High Pressure Relief Valve

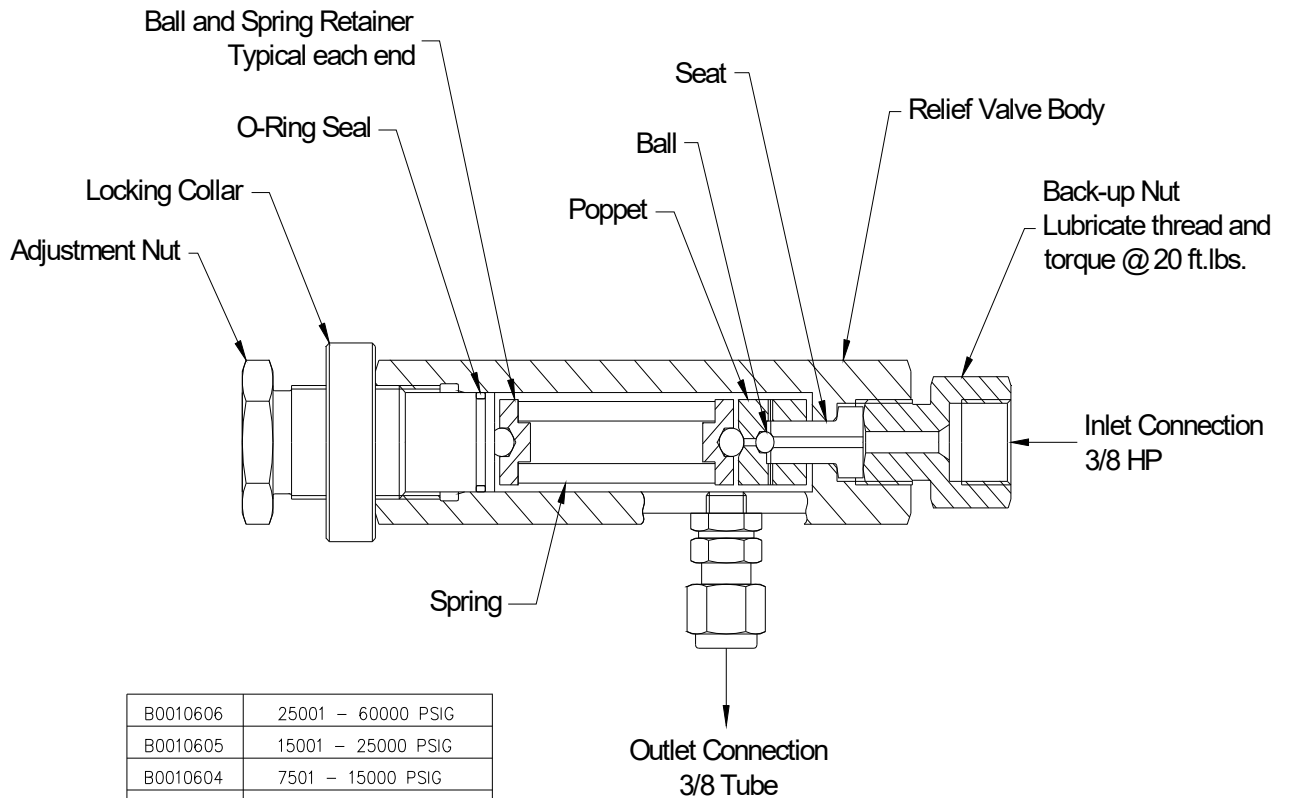

B0010606	25001 – 60000 PSIG
B0010605	15001 – 25000 PSIG
B0010604	7501 – 15000 PSIG
B0010603	3501 – 7500 PSIG
B0010602	1501 – 3500 PSIG
B0010601	500 – 1500 PSIG
PART NO.	PRESSURE RANGE

Low Pressure Relief Valve

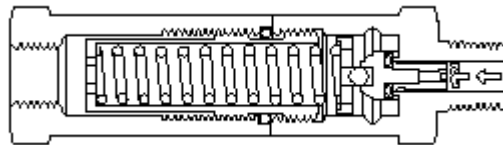

CLOSED

The spring load is carried by a metal-to-metal seat. The O-ring provides a dead tight seal. Sealing efficiency increases as the pressure increases up to the cracking pressure.

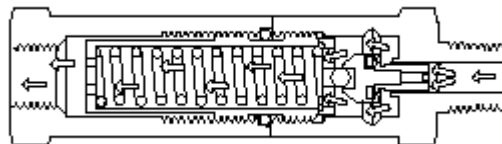

CRACKING

The ports in poppet open fully and eliminate rapid increase in the pressure. The flow is throttled between the poppet shoulder and the seat, which provides regularly increasing flow area with increasing flow rates.

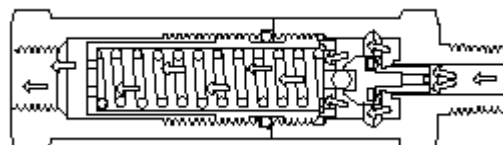

OPEN

The inline construction and full flow ports permit maximum flow with minimum increase in the system pressure.

Injection Pump (typical)

CONNECTIONS

- V-(1) 3/8 NPT PRIMING PUMP INLET
- W-(1) 3/8 NPT PRIMING PUMP OUTLET
- X-(2) 1/4 NPT INJ. PUMP INLETS
PLUG ONE WITH PIPE PLUG
- Y-(1) 1/4 NPT INJ. PUMP OUTLET
- Z-(2) 1/4 NPT CAM LUBRICATION
INLET & OUTLET

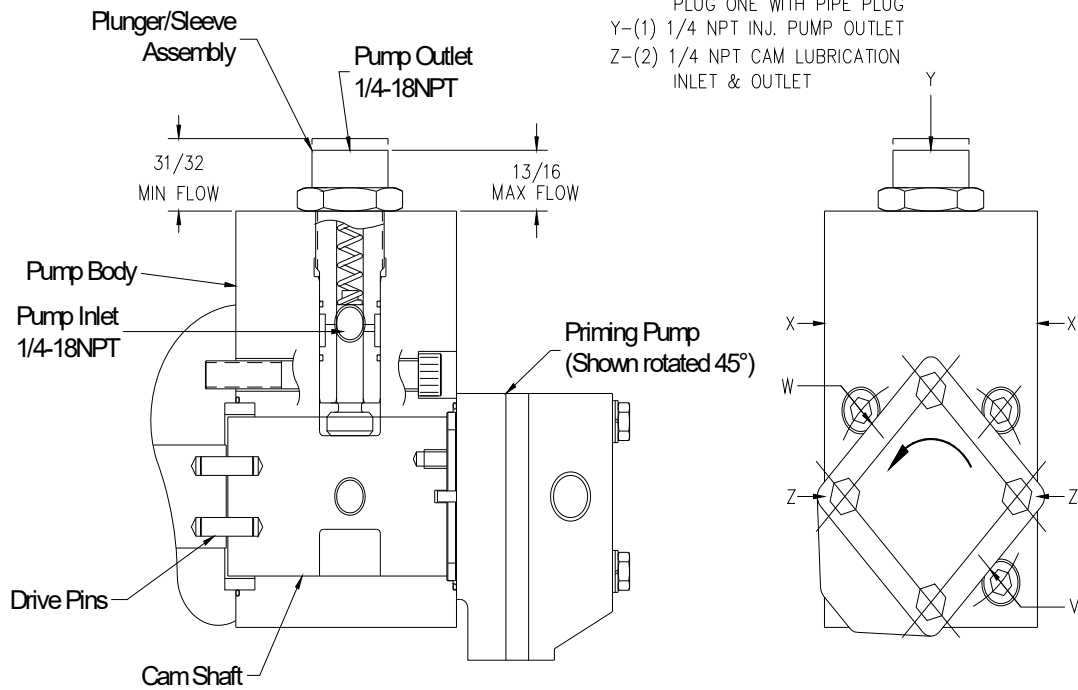

NOTES:

1. PHASE INJECTION PUMP CAMSHAFT SUCH THAT INJECTION PUMP PLUNGER IS @ T.D.C. WHEN COMP. BASE PISTON IS AT B.D.C.
2. DIMENSIONS GIVEN FOR MAX & MIN FLOW ARE APPROXIMATE.

Belt Tightening Procedures

Installing A Drive

Here are a few suggestions to keep in mind when installing the drive:

1. Use a matched set of belts.
2. Clean oil and grease from the sheaves; remove any rust or burrs from the sheave grooves.
3. Shorten the center distance of the drive until the belts can be put on the sheaves without forcing.
4. Make sure that the sheaves are correctly aligned, that the shafts are parallel, that there is clearance for the drive to run and that the bearings have oil.
5. Work belts around in the groove by hand, so that the slack of **all** belts is on the top, or slack of **all** belts is on the bottom.

LIKE THIS:
(all slack at top)



OR LIKE THIS:
(all slack at bottom)



DO NOT APPLY THIS WAY:
(with slack at top and bottom)



Do not apply with the slack of some belts on the bottom (see solid line) and the slack of others on the top (see dotted line). Since V-belts will not slide in the groove, belts thus applied will be injured when tightened for operation.

Now tension the drive until only a slight bow appears on the slack side of the belts when they are operating.

6. In a day or so, when the belts have had time to seat in the grooves, re-tension the belts.

All V-belt drives should be guarded in such a manner as to comply with the Williams-Steiger Occupational Safety and Health Act and with all state and local laws and the American National Standard Institute (ANSI) safety code.

Tensioning The Drive

General Rules of Tensioning:

1. Ideal tension is the lowest tension at which the belt will not slip under peak load conditions.
2. Check tension frequently during the first 24-48 hours of run-in operation.
3. Overtensioning shortens belt and bearing life.
4. Keep belts free from foreign material which may cause slip.
5. Make V-drive inspection on a periodic basis. Tension when slipping.

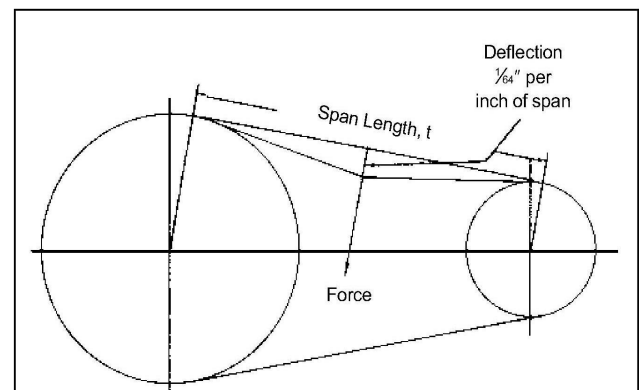

Test The Tension

If you want to check the tension in a conventional V-belt drive, use the procedure below:

1. Measure the span length, t .
2. At the center of the span (t) apply a force (perpendicular to the span) large enough to deflect the belt $\frac{1}{64}$ " for every inch of span length. For example, the deflection of a 100 inch span would be $1\frac{1}{16}$ inches.
3. Compare the force you have applied with the values given in Table 12. If the force is between the values for normal tension, and $1\frac{1}{2}$ times normal tension, the drive tension should be satisfactory. A force below the value for normal tension indicates an under-tensioned drive. If the force exceeds the value for $1\frac{1}{2}$ times normal tension, the drive is tighter than it needs to be. A new drive can be tightened initially to two times normal tension to allow for the normal drop in tension during run in.

Installation and Take-up Allowances

After calculating a center distance from a standard pitch length, make provision for adjusting the center distance as in Table 13, to allow for installation of the belts without injury, for tensioning, and for maintenance of proper tension throughout the life of the belt.

Table 12 — Belt Deflection Force

V-Belt Cross Section	Smallest Sheave Diameter Range	RPM Range	Belt Deflection Force			
			A, B, C, D		AX, BX, CX	
			Normal	1½ × Normal	Normal	1½ × Normal
A	3.0-3.6	1000-2500	3.7	5.5	4.1	6.1
		2501-4000	2.8	4.2	3.4	5.0
	3.8-4.8	1000-2500	4.5	6.8	5.0	7.4
		2501-4000	3.8	5.7	4.3	6.4
	5.0-7.0	1000-2500	5.4	8.0	5.7	9.4
		2501-4000	4.7	7.0	5.1	7.6
B	3.4-4.2	860-2500			4.9	7.2
		2501-4000			4.2	6.2
	4.4-5.6	860-2500	5.3	7.9	7.1	10.5
		2501-4000	4.5	6.7	7.1	9.1
	5.8-8.6	860-2500	6.3	9.4	8.5	12.6
		2501-4000	6.0	8.9	7.3	10.9
C	7.0-9.0	500-1740	11.5	17.0	14.7	21.8
		1741-3000	9.4	13.8	11.9	17.5
	9.5-16.0	500-1740	14.1	21.0	15.9	23.5
		1741-3000	12.5	18.5	14.6	21.6
D	12.0-16.0	200-850	24.9	37.0		
		851-1500	21.2	31.3		
	18.0-20.0	200-850	30.4	45.2		
		851-1500	25.6	38.0		

V-Belt Cross Section	Smallest Sheave Diameter Range	RPM Range	Belt Deflection Force			
			3V, 5V, 8V		3VX, 5VX	
			Normal	1½ × Normal	Normal	1½ × Normal
3V	2.2-2.4	1000-2500			3.3	4.9
		2501-4000			2.9	4.3
	2.65-3.65	1000-2500	3.6	5.1	4.2	6.2
		2501-4000	3.0	4.4	3.8	5.6
	4.12-6.90	1000-2500	4.9	7.3	5.3	7.9
		2501-4000	4.4	6.6	4.9	7.3
5V	4.4-6.7	500-1749			10.2	15.2
		1750-3000			8.8	13.2
		3001-4000			5.6	8.5
	7.1-10.9	500-1740	12.7	18.9	14.8	22.1
		1741-3000	11.2	16.7	13.7	20.1
	11.8-16.0	500-1740	15.5	23.4	17.1	25.5
		1741-3000	14.6	21.8	16.8	25.0
8V	12.5-17.0	200-850	33.0	49.3		
		851-1500	26.8	39.9		
	18.0-22.4	200-850	39.6	59.2		
851-1500		35.3	52.7			

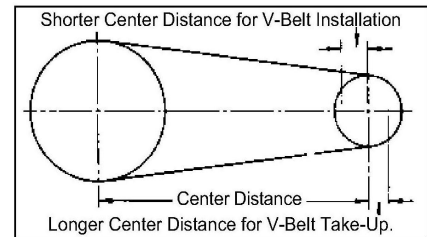

Table 13 — Center distance allowance for installation and take-up

Standard Length Designation	Minimum Allowance Below Standard Center Distance for Installation of Belts (Inches)								Minimum Allowance Above Standard Center Distance for Maintaining Tension (Inches) All Sections
	A, AX	A, AX Joined	B, BX	B, BX Joined	C, CX	C, CX Joined	D	D Joined	
26 to 37	0.75	1.20	1.00	1.50					1.00
38 to 59	0.75	1.20	1.00	1.50	1.50	2.00			1.50
60 to 89	0.75	1.30	1.25	1.60	1.50	2.00			2.00
90 to 119	1.00	1.30	1.25	1.60	1.50	2.00			2.50
120 to 157	1.00	1.50	1.25	1.80	1.50	2.10	2.00	2.90	3.00
158 to 194			1.25	1.80	2.00	2.20	2.00	3.00	3.50
195 to 239			1.50	1.90	2.00	2.30	2.00	3.20	4.00
240 to 269			1.50	2.00	2.00	2.50	2.50	3.20	4.50
270 to 329			1.50	2.20	2.00	2.50	2.50	3.50	5.00
330 to 419					2.00	2.70	2.50	3.60	6.00
420 and over					2.50	2.90	3.00	4.10	1.5% of belt length

Standard Length Designation	Minimum Allowance Below Standard Center Distance for Installation of Belts (Inches)						Minimum Allowance Above Standard Center Distance for Maintaining Tension (Inches) All Cross Sections
	3V, 3VX	3V, 3VX Joined	5V, 5VX	5V, 5VX Joined	8V	8V Joined	
Up to and incl. 475	0.5	1.2					1.0
Over 475 to and incl. 710	0.8	1.4	1.0	2.1			1.2
Over 710 to and incl. 1060	0.8	1.4	1.0	2.1	1.5	3.4	1.5
Over 1060 to and incl. 1250	0.8	1.4	1.0	2.1	1.5	3.4	1.8
Over 1250 to and incl. 1700	0.8	1.4	1.0	2.1	1.5	3.4	2.2
Over 1700 to and incl. 2000			1.0	2.1	1.8	3.6	2.5
Over 2000 to and incl. 2360			1.2	2.4	1.8	3.6	3.0
Over 2360 to and incl. 2650			1.2	2.4	1.8	3.6	3.2
Over 2650 to and incl. 3000			1.2	2.4	1.8	3.6	3.5
Over 3000 to and incl. 3550				2.4	2.0	4.0	4.0
Over 3550 to and incl. 3750					2.0	4.0	4.5
Over 3750 to and incl. 5000					2.0	4.0	5.5

Warranty Terms and Conditions

PDC, , (hereafter referred to as "Company), guarantees its products to be free from defect in material and workmanship under normal use and service for a period of one and one-half years from the date of shipment or one year from the date of installation, whichever comes first, being subject to the following limitations:

- 1) Company makes no warranties regarding equipment manufactured by it or others (including without limitation warranties as to merchantability and fitness for a purpose), either expressed or implied, except as provided hereunder. The foregoing shall constitute the exclusive remedies of purchaser for any breach by company or its warranties hereunder, and seller further expressly waives and disclaims any liability for incidental or consequential damages.
- 2) Where equipment sold hereunder is used with attachments and/or modifications, which have not been recommended or approved by Company in writing, such use shall not be considered normal use and service under this guarantee and this guarantee shall not apply.
- 3) This guarantee does not extend to, and Company assumes no liability for, consequential and/or secondary damages, or losses of any kind sustained directly or indirectly as a result of a defect in any equipment, material or installation. Company shall, in no event, be liable in any amount exceeding the purchase price of the equipment and transportation charges thereon.
- 4) This guarantee extends only to the repair of any or all defective material, part, or assemblies which may be returned, prepaid by the buyer, to Company's factory for repair and returned thereof at Company's expense, to the buyer; or, at the Company's option and at Company's expense, Company will supply replacement parts to the buyer upon receipt by Company of the defective material or assemblies. Company shall not be liable for the cost and expense of any repair or installation of replacement parts hereunder unless the same is accompanied under the direct supervision of Company or pursuant to its written authority.
- 5) All equipment sold is guaranteed to function in accordance with the current Company equipment specification, if installed and operated in strict accordance with accompanying installation manuals, but the buyer shall be solely responsible for determining suitability for use and the Company shall in no event be liable in this respect. Company reserves the right to determine if any equipment has been subject to misuse or misapplication beyond Company's specifications.
- 6) Company makes no guarantee whatsoever with respect to equipment, material, or parts supplied or manufactured by others, and such equipment, materials or parts will be repaired or replaced only to the extent of the original supplier's or manufacturer's guarantee.
- 7) This guarantee does not extend to, and the Company assumes no liability for, any damage or destruction of the equipment sold hereunder as a result of improper or unauthorized service. The buyer is cautioned that appropriate and effective service may be essential for proper working of the products sold hereby. The Company reserves the right in its sole discretion to determine whether service to the equipment has been proper or whether such service has voided the warranties herein discussed.

8) All non-wear components, for example, process/hydraulic heads, crankcases are conditionally included in this warranty. Wear components, for example: filters, diaphragms, check valves, oil relief valves and o-rings are excluded.

REVISION HISTORY:

Rev 4: Revised from original Manual

Rev 4b: Added Oil Note on Page 41 JE 2/5/19

Added Document Number AA 2/5/19

Rev 5 Updated Warranty Terms
and Conditions and Logo Bree McQuillan 1/4/22

Rev 6 changed all 3000 hour reference
To 4000 hours. Tom P 3/9/23

Rev 7 added lubricant list & FR series oil Tom P 3/20/23